

## GROUP 48 POWER TAKE-OFF

### Description

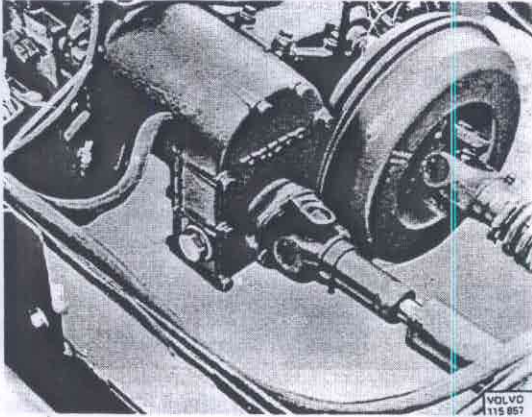

Fig. 48-1. Power take-off

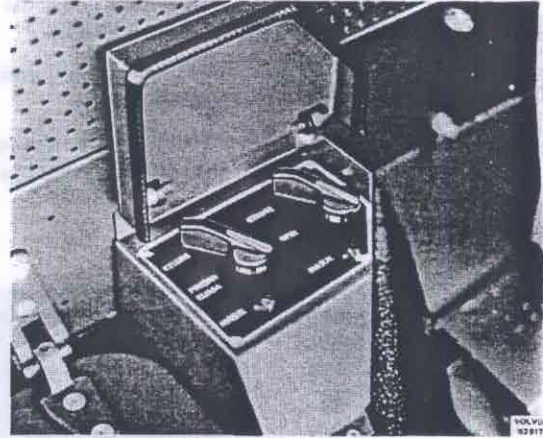

Fig. 48-2. Control for power take-off

### POWER TAKE-OFF

For driving optional equipment, for example, a winch, a power take-off can be connected to the auxiliary gearbox. This type of power take-off is seen in Fig. 48-1.

The construction of the power take-off can be seen from Illustration 48-A. The power take-off housing is of aluminium and consists of two halves. Journalled in the housing is an input and an output shaft. On the

input shaft is a flange, which is meshed with the drive gear of the auxiliary gearbox. The output shaft is driven via a gear on the input and the output shafts which are in constant mesh.

The power take-off is engaged by a control, Fig. 42-2, located at the side of the engine casing, which is connected to the vehicle vacuum system. When the power take-off is engaged, see Fig. 48-3 and 48-4, its bellows are actuated by a vacuum and the flange engages with the auxiliary gearbox drive gear.

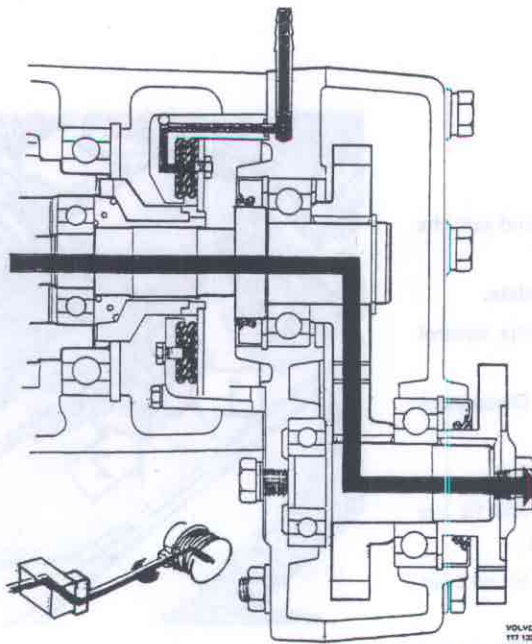

Fig 48-3 Power take-off is engaged

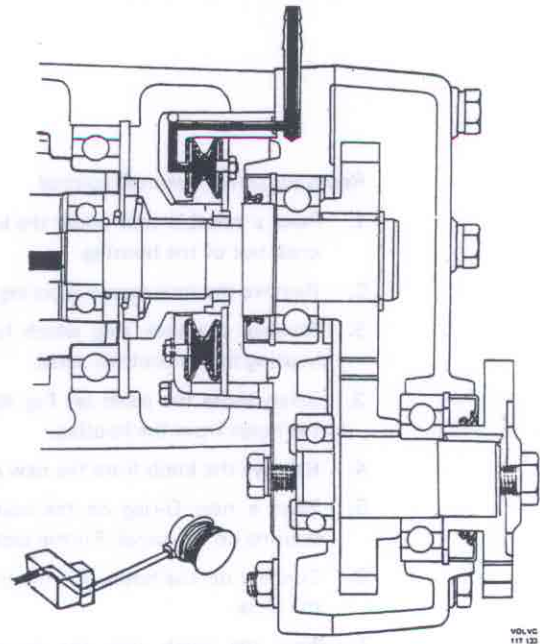

Fig 48-1 Power take-off is disengaged

## Service procedures

Work which can be done in the vehicle

### Replacing the O-ring on the control crank

1. Place a suitable tool under the handle, and pull the handle out of the housing.
2. Replace the O-ring on the handle Fig. 48-5 and coat it with a little grease.
3. Press the handle into the housing. Check to make sure that the differential lock can be engaged and disengaged.

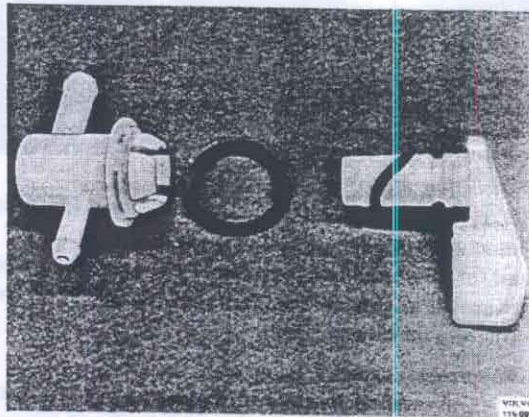

Fig. 48-4. Power take-off controls

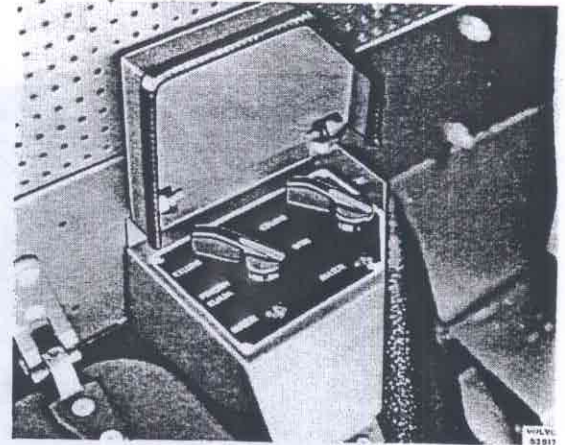

Fig. 48-5. Removing the housing

### Removing of power take-off from auxiliary gearbox

1. Remove the propeller shaft.
2. Drain the oil from the power take-off by removing the screw (2, Fig. 48-6).
3. Remove the bolts securing the cover in the power take-off housing.

### Replacing power takeroff control

1. Place a suitable tool under the knob and pull the knob out of the housing.
2. Remove the four screws securing the plate.
3. Remove the lock ring which holds the control housing to the controls panel.
3. Screw loose the panel see Fig. 48-5. Disconnect the hoses from the housing.
4. Remove the knob from the new control.
5. Place a new O-ring on the housing and fit the housing on the panel. Fit the lock ring.
6. Connect up the hoses. Fit the panel. Screw tight the plate.
7. Press the knob into the housing. Check the function of the power take-off.

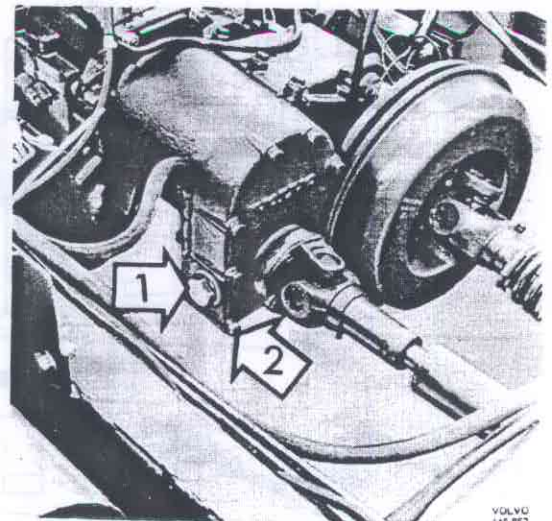

Fig. 48-6. Drain the oil

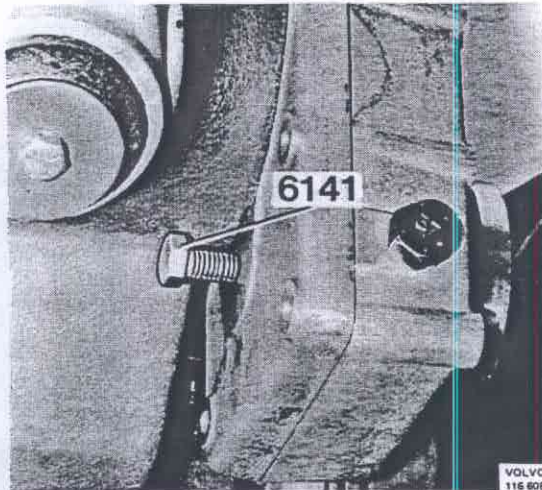

Fig. 48-7. Removing cover

4. Remove the plug, on the power take-off housing. Screw in the separating bolt 6141, Fig. 48-7 and press the cover from the housing. Remove the bolt and push in the plug again.
5. Remove both the inhex bolts, Fig. 48-8, securing the housing to the auxiliary gearbox.

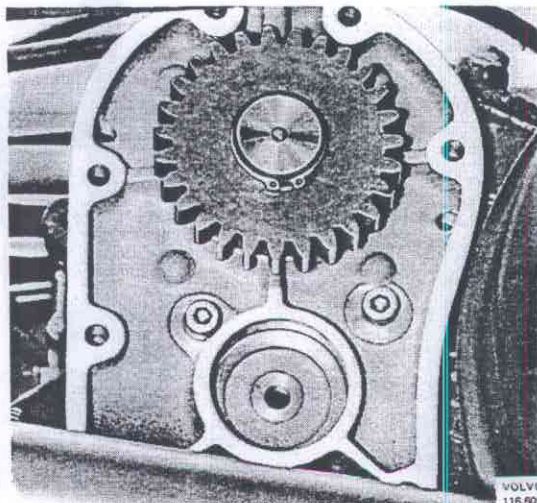

Fig. 48-8. Remove the inner bolts

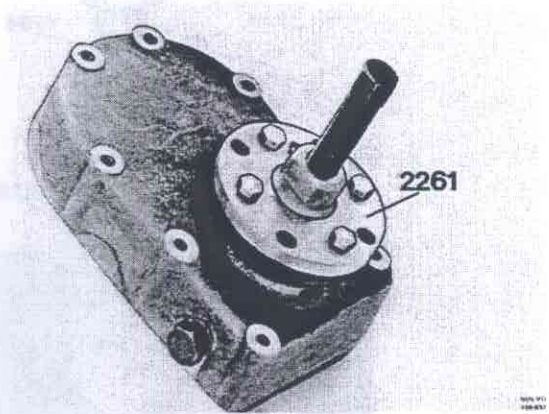

Fig. 48-9. Removing flange

### Disassembling the power take-off

Special tools: 1784, 1801, 2014, 2022, 2261, 2873.

#### Rear housing half

1. Clean the power take-off. Fit counterhold 2873 on the flange and remove the bolt and washer securing the flange.
2. Pull off the flange using 2261, see Fig. 48-9.
3. Press out the output shaft and bearing with 1784, see Fig. 48-10.
4. Remove the key from the shaft.
5. Place the shaft in 2022 and press off the bearing using 1784, see Fig. 48-11.

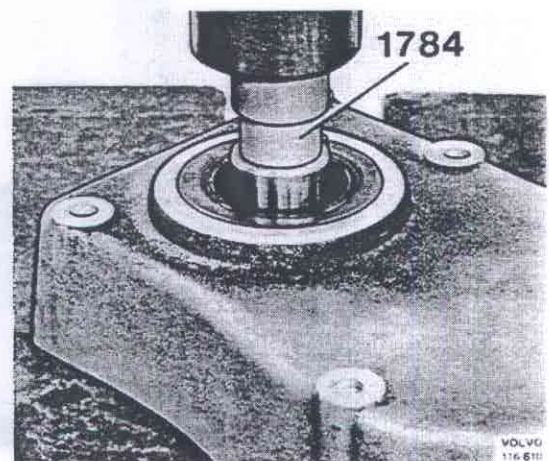

Fig. 48-10. Removing shaft

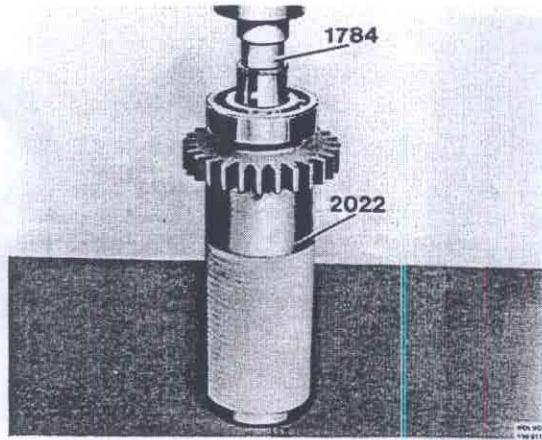

Fig. 48-11. Removing bearing

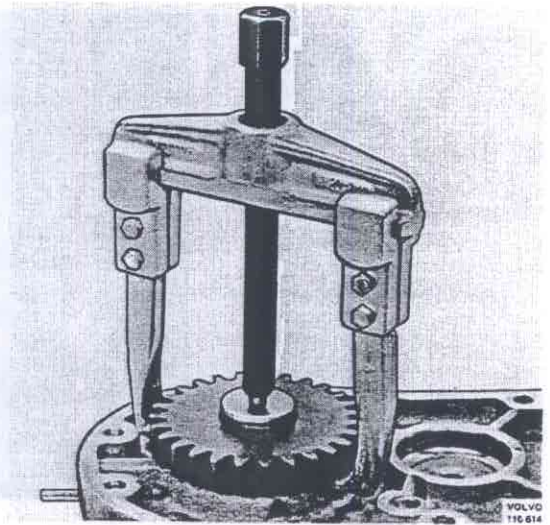

Fig. 48-14. Removing the drive

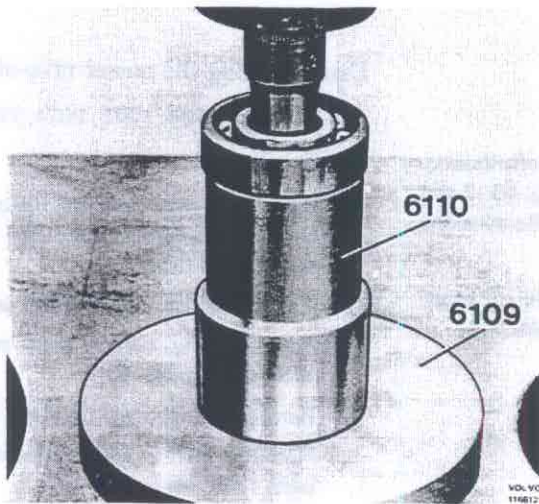

Fig. 48-12. Removing the inner bearing

6. Place the shaft in 6110 and press off the inner bearing, see Fig. 48-12.
7. Remove the circlip in the housing and press out the seal with 1801 + 2014, see Fig. 48-13.

**Front housing half**

1. Remove the circlip on the input shaft and pull off the drive with a standard puller, see Fig. 48-14.

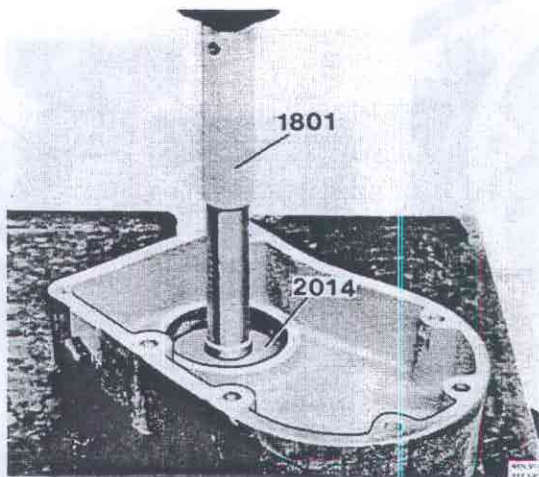

Fig. 48-13. Removing the seal

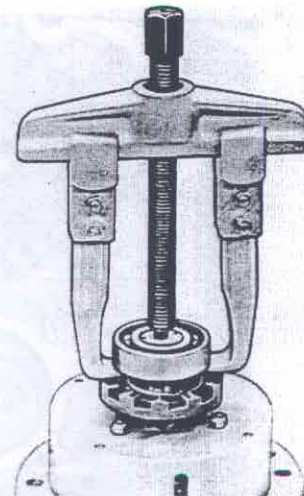

Fig. 48-15. Removing bearing

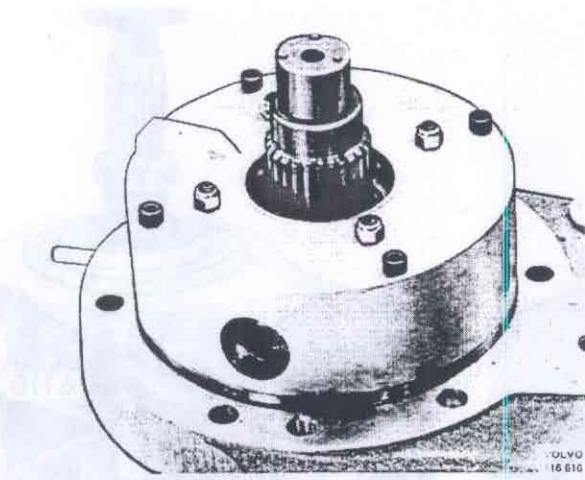

Fig. 48-16. Removing the bolts

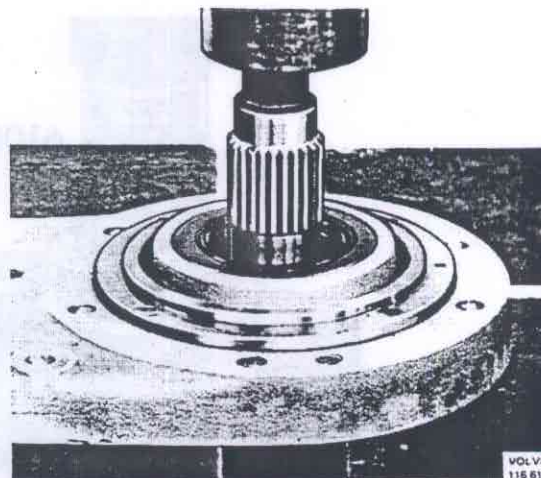

Fig. 48-18. Pressing out the shaft

2. Pull the support bearing off the shaft with a standard puller, see Fig. 48-15. Remove the spring and flange.
3. Remove the retaining bolts (in hex 3 mm = 1/8") holding the control housing, see Fig. 48-16. Remove the housing.
4. Remove the nuts securing the thrust plate, Fig. 48-17, to the bellows.
5. Remove the nuts securing the bellows to the control housing and take out the bellows.
6. Remove the circlip from the input shaft. Press out the shaft and bearing, see Fig. 48-18, from the housing.
7. Remove the key from the shaft.
8. Place the shaft in 2022 and press off the bearing using 1784, see Fig. 48-19.
9. Remove the circlip from the housing and press out the seal with 1801 + 2014.

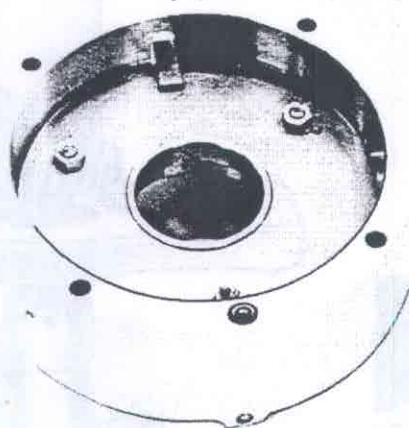

Fig. 48-17. Removing the nuts

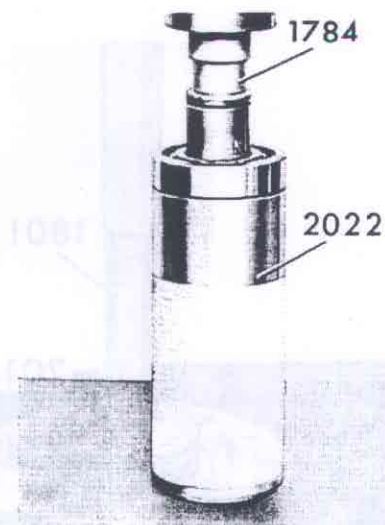

Fig. 48-19. Removing the bearing

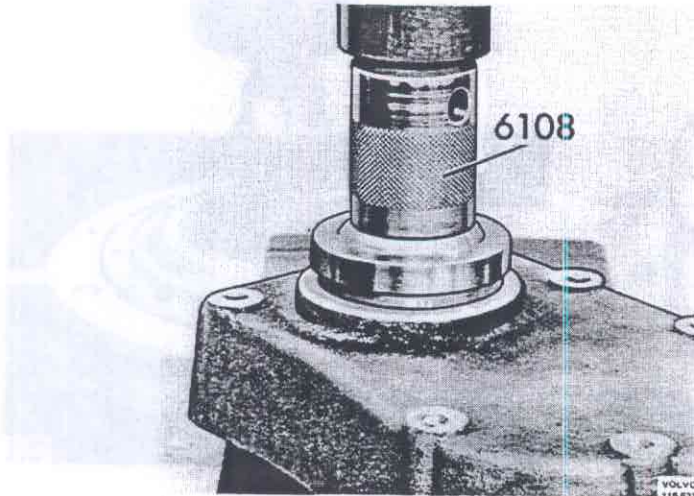

Fig. 48-20. Pressing in the seal

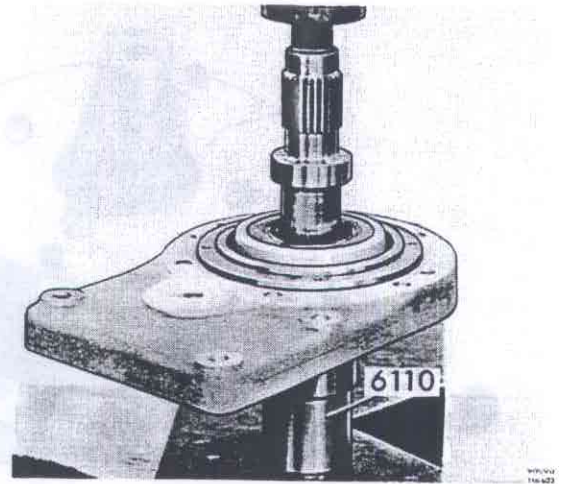

Fig. 48-22. Pressing in the shaft

### Checking and replacing parts

Clean all parts and check them for damage and wear. All damaged or worn parts should be replaced, but sealing rings, O-rings and gaskets must always be replaced. When replacing sealing rings, check carefully the surfaces which have been covered by these rings. If a surface is scored or damaged in any other way, then the particular component with the damaged surface must be replaced.

### Assembling

Special tools: 1801, 2014, 2022, 6108, 6110

#### Assembling the front housing half

1. Place the circlip nearest the sealing in the housing.
2. Place the sealing in the housing with 6108, see Fig. 48-20.
3. Press the bearing into the housing using 1801 + 2014, see Fig. 48-21. Place the circlip which secures the bearing.
4. Place the housing on 6110, see Fig. 48-22, and press in the input shaft.

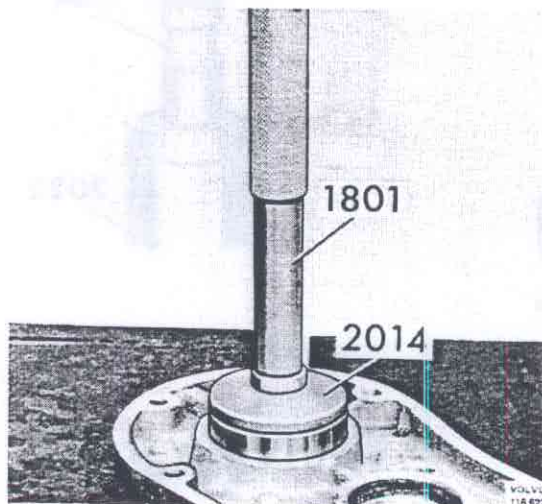

Fig. 48-21. Pressing in the bearing

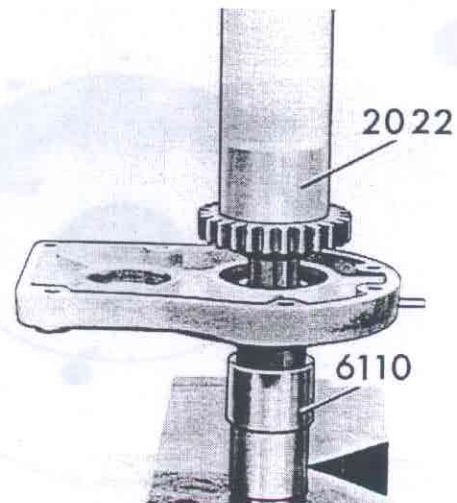

Fig. 48-23. Pressing on the wheel

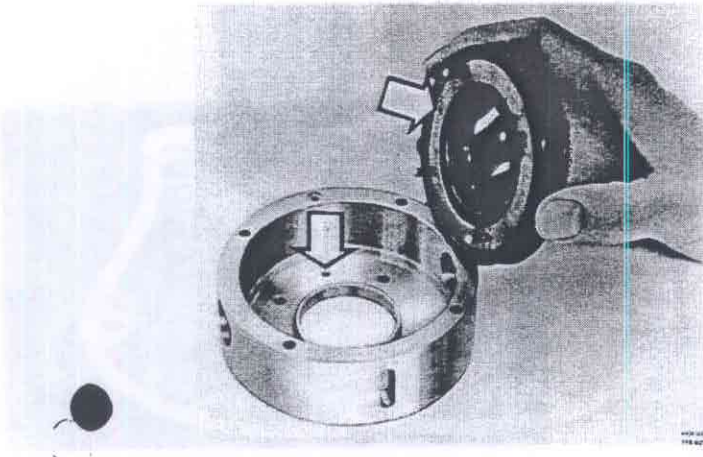

Fig. 48-24. Removing the bellows

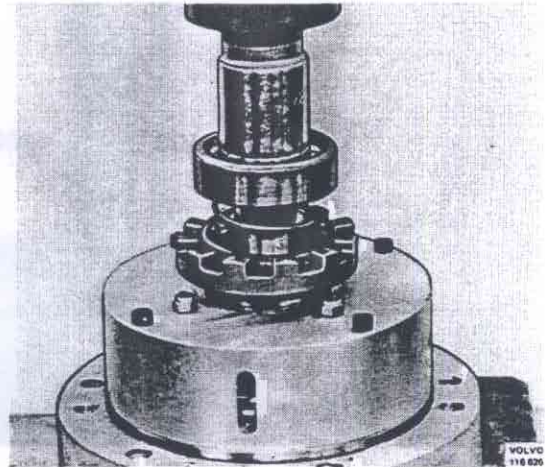

Fig. 48-26. Pressing on the bearing

5. Secure the key for the gear wheel. Place the housing on 6110 and press on the gear wheel with 2022, see Fig. 48-23. Secure the circlip for the gear.
6. Place the bellows on the control housing.  
NOTE! Make sure that the hole in the bellows is opposite the hole in the housing, see Fig. 48-24. Tighten up the bellows.
7. Make sure the bushing is firmly in position by peening it at three points. Place the plate in position and tighten it with the bellows.
8. Place a new O-ring on the control housing, see Fig. 48-25. Assemble the control housing to the housing half. Make sure that the air duct is located properly.
9. Place the flange and the thrust spring on the input shaft, see Fig. 48-26.
10. Press on the support bearing and peen it with three punch pops, see Fig. 48-27.

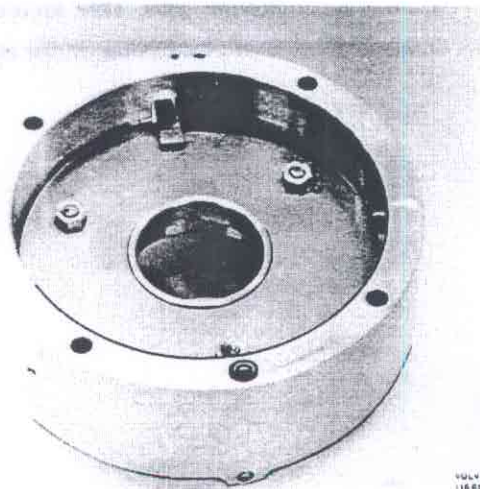

Fig. 48-25. Fitting the O-ring

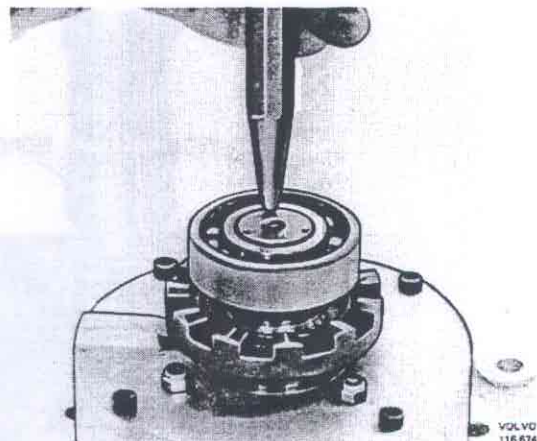

Fig. 48-27. Penning the bearing

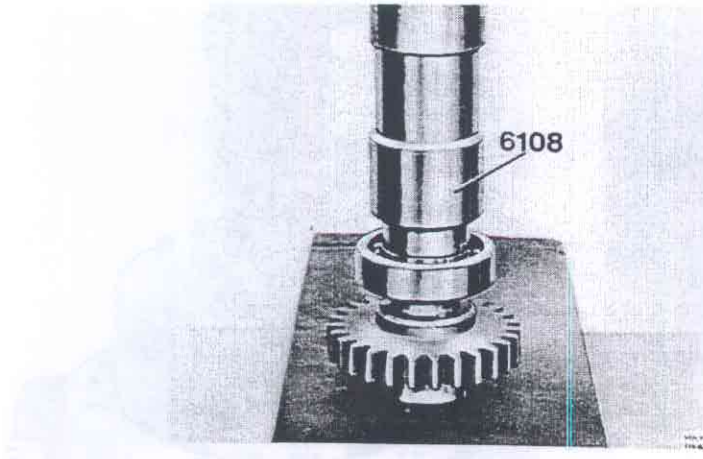

Fig. 48-28. Pressing on the wheel

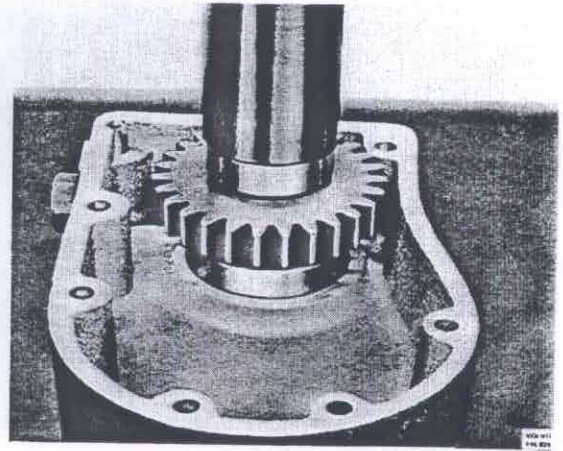

Fig. 48-30. Pressing on the shaft

**Rear housing half**

1. Press the support bearing on the output shaft.
2. Press on the gear wheel with 6110, see Fig. 48-28.
3. Press on the rear bearing with 6110, see Fig. 48-29. Fix the flange key in position.
4. Fit the circlip on the housing half.
5. Press the seal into the housing with 6108. Coat the seal with grease.
6. Press the output shaft into the housing, see Fig. 48-30.
7. Press the flange on the output shaft. Place the washer on the flange and tighten up the bolt to a torque of 41-51 Nm (4.1-5.1 kpm = 30-37 lbftf).

**Installing the power take-off on the auxiliary gearbox**

1. Clean the contact surface on the auxiliary gearbox and coat it with sealing agent.
2. Fit the front housing half on the gearbox. Tighten the bolts to a torque of 20-25 Nm (2.0-2.5 kpm = 14-18 lbftf).
3. Coat the rear housing half contact surface with sealing agent. Mount the housing on the gearbox, turn the flange while putting the housing halves together. Tighten the bolts to a torque of 20-25 Nm (2.0-2.5 kpm = 14-18 lbftf). Fit the ventilation hose.
4. Fit the propeller shaft and tighten the bolts to a torque of 55-65 Nm (5.5-6.5 kpm = 40-47 lbftf).
5. Fill the power take-off with oil. Concerning quantity and quality, see under "Data".
6. Check the function of the power take-off.

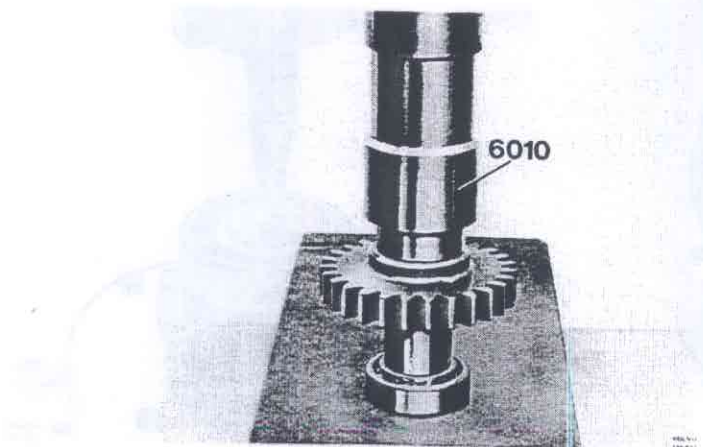

Fig. 48-29. Pressing on the bearing



Power take-off

- 1. Gear
- 2. Shaft
- 3. Gear
- 4. Gear
- 5. Gear
- 6. Gear
- 7. Gear
- 8. Gear
- 9. Gear
- 10. Gear
- 11. Gear
- 12. Gear
- 13. Gear
- 14. Gear
- 15. Gear
- 16. Gear
- 17. Gear
- 18. Gear
- 19. Gear
- 20. Gear
- 21. Gear
- 22. Gear
- 23. Gear
- 24. Gear
- 25. Gear
- 26. Gear
- 27. Gear
- 28. Gear
- 29. Gear
- 30. Gear

**Illustration 48-A. Power take-off**

**Power take-off**

- 1 Spring
- 2 Flange
- 3 Bushing
- 4 Nut
- 5 Contral housing
- 6 Ball
- 7 Attaching plate
- 8 Bellows
- 9 Support plate
- 10 Trust plat
- 11 Input shaft
- 12 Key
- 13 Seal
- 14 Housing
- 15 O-ring
- 16 Circlip
- 17 Bearing
- 18 Circlip
- 19 Drive wheel
- 20 Circlip
- 21 Housing
- 22 Bearing
- 23 Flange
- 24 Washer
- 25 Screw
- 26 Screw
- 27 Bearing
- 28 Output shaft
- 29 Key
- 30 Wheel
- 31 Bearing
- 32 Circlip
- 33 Screw

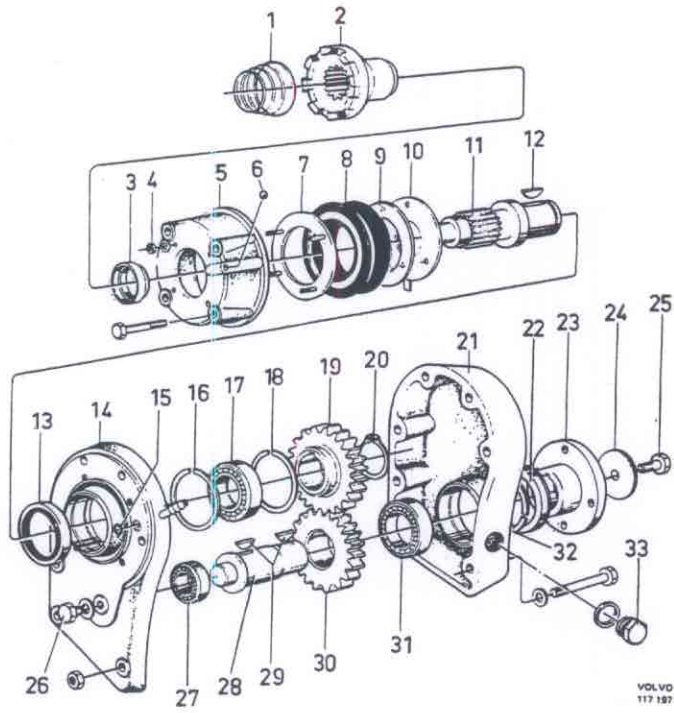

VOLVO  
117-187