

Contact for brake pedal travel, adjustment measurement

### Contact for parking brake

36422-2

#### Replacing

1. Remove the inspection cover.

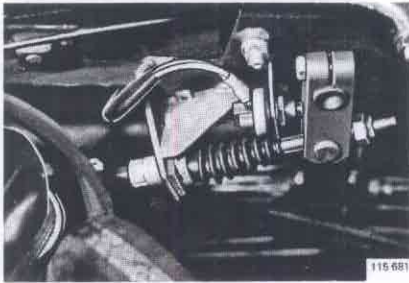

2. Disconnect the cable and remove the nut securing the contact to the bracket.
3. Fit and tighten up the new contact to the bracket and connect the cable. The contact should cut in the circuit to the warning light marked "Brake" at the second or third ratchet notch. Put back the inspection cover.

### Contact for reversing lights

#### Replacing

1. Remove the cover from over the gearbox.
2. Disconnect the cable and remove the contact.
3. Fit the new contact and connect up the cable.

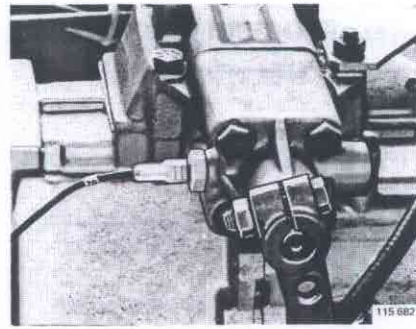

4. Put back the cover over the gearbox.

### Vacuum contact for diff. locks

38240-2

#### Replacing

1. Disconnect the cable from the contact.
2. Remove the contact.
3. Fit the new contact and connect up the cable.

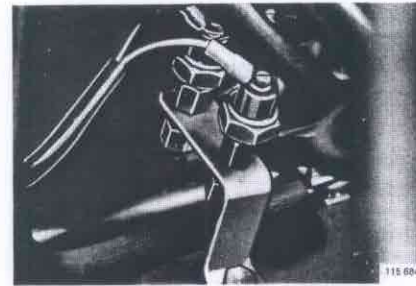

### Contact for front-wheel drive (underneath instrument panel)

36452-2

#### Replacing

Have a new contact and gasket ready for fitting. Disconnect the cable and unscrew the contact. Quickly fit the new contact and gasket. Connect up the cable. Check the level in the brake fluid containers and test the brakes.

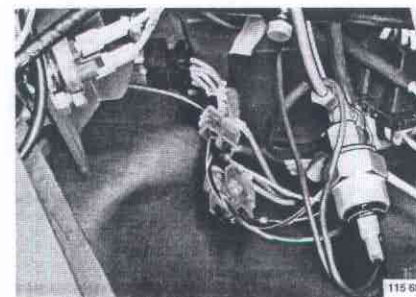

## Contact for front-wheel drive (at transfer box)

### Removing

Remove the cover from over the gearbox.

Mark for correct re-installation and disconnect the cables from the contact.

Remove the contact and copper washer.

### Installing

Screw in the contact together with a new copper washer.

Connect up the cables according to the marking.

Put back the cover over the gearbox.

## Panel lights

### 8161-3

#### Replacing a bulb

Unscrew the panel light lens and remove the bulb.

Fit the new bulb and screw on the lens.

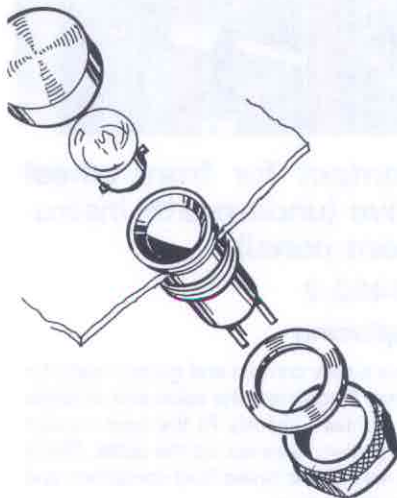

## Removing a panel light

1. Remove the cover from over the batteries and disconnect the negative cable from the battery.
2. Screw off the panel light lens.
3. Mark the cables for correct re-installation and disconnect them from the panel light.
4. Unscrew the nut securing the panel light and withdraw the light from the panel.

## Installing a panel light

1. Fit the new panel light and tighten it to the panel with the nut.
2. Connect up the cables according to the marking.
3. Fit a new bulb if necessary and screw on the lens.
4. Connect up the negative cable to the battery and re-fit the cover over the batteries.

## List of electrical components

letter and figure within brackets indicat the square in which the component is placed

ilb, direction indicators	(A1)	64 Reversing light contact	(D2)
ilb, parking lights	(A1)	65 Contact, parking brake	(D2)
ilb, fullbeams and dipped beams	(A1)	66 Starter motor	(D2)
indscreen wipers	(A1)	67 Battery	(D2)
lay, headlight flasher	(A2)	68 Distributor	(D3)
lay, parking lights	(A2)	69 Capacitor	(D3)
ep relay, fullbeams and dipped beams	(A2)	70 Ignition coil	(D3)
lay, headlamp ipers	(A2)	71 Charging regulator	(D3)
orn button	(A2)	72 Alternator	(D3)
orn	(A2)	73 Contact, oil pressure	(D3)
adlamp wiper	(A3)	74 Contact, front-wheel drive	(D4)
adlamp wiper	(A3)	75 Contact, front-wheel drive	(D4)
adlamp washers	(A3)	76 Solenoid valve	(D4)
lay, windscreen wiper	(A3)	77 Switch, interior lighting	(D4)
lay, windscreen wiper	(A3)	78 Bulb, interior light	(D4)
lay, windscreen wiper	(A3)	79 Bulb, tail light	(E1)
indscreen washers	(A3)	80 Bulb, direction indicator	(E1)
indscreen wiper	(A3)	81 Bulb, stop lights	(E1)
lay, windscreen wipers	(A3)	82 Trailer contact	(E3)
lb, fullbeams and dipped beams	(A4)	83 Bulb, reversing lights	(E4)
lb, parking light	(A4)	84 Bulb, tail light	(E4)
lb, direction indicator	(A4)	85 Bulb, direction indicator	(E4)
n motor, extra	(B2)	86 Bulb, stop light	(E4)
vitch, fan motor	(B2)		
n motor	(B2)		
ntact, front-wheel drive	(B2)		
ntact, brake pedal movement	(B2)		
arning light, battery charging	(B3)		
arning light, oil pressure	(B3)		
arning light, brakes	(B3)		
eoostat	(B3)		
licator light, fullbeams	(B3)		
olant temperature gauge	(B3)		
licator light, direction indicator	(B3)		
sher device	(B3)		
licator light, direction indicator	(B3)		
eedometer	(B3)		
el gauge	(B4)		
ritch, windscreen wash	(B4)		
ritch, hazard warning lights	(B4)		
ritch, headlamp wipers	(B4)		
ritch, windscreen wiper	(B4)		
ritch, windscreen wiper	(B4)		
ritch, lights	(B4)		
g socket	(C1)		
ike light contact	(C2)		
ection indicator stalk	(C2)		
ay, reversing lights	(D2)		
ntact, brake circuit	(D2)		
ark plugs	(D2)		
mpor resistance	(D2)		
ntact, differential lock	(C3)		
ntact, differential lock	(C3)		
icator light, differential lock	(C4)		
ider, coolant temperature gauge	(C4)		
icator light, differential lock	(C4)		
icator light, front-wheel drive	(C4)		
ition switch	(C4)		
al level sender	(D1)		
ole, connector	(D1)		
ole, connector	(D1)		

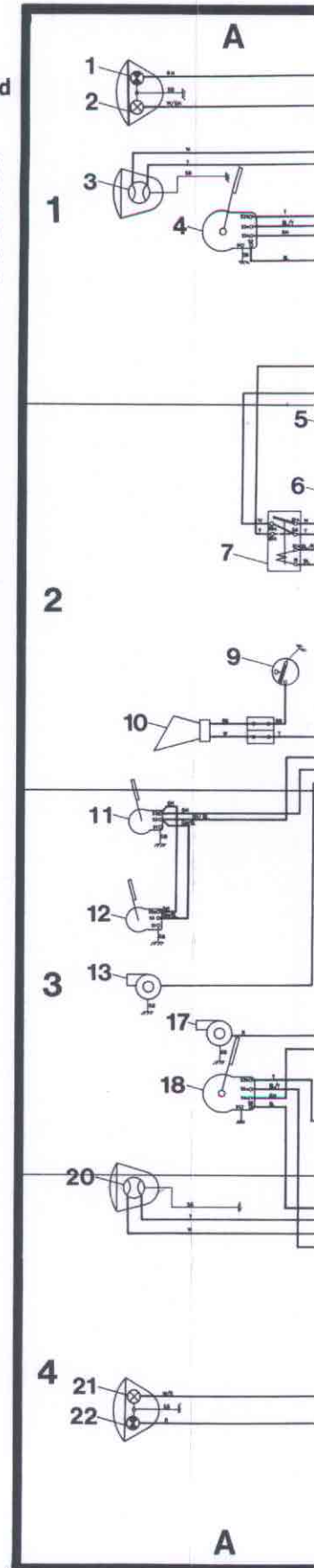

## List of Operation Numbers

### Group

Op.No.	Description	Page
31102-3	Replacing the battery .....	7

### Group

Op.No.	Description	Page
32170-1	Removing the alternator .....	10
32172-1	Installing the alternator .....	14
32174-2	Charging test .....	14
32205-3	Replacing the charging regulator .....	14

### Group

Op.No.	Description	Page
33170-1	Removing the starter motor .....	18
33172-1	Installing the starter motor .....	25
33175-5	Replacing the field coils .....	22

### Group

Op.No.	Description	Page
34202-2	Replacing the breaker contacts .....	32
34276-2	Adjusting the ignition .....	31

### Group

Op.No.	Description	Page
5303-3	Replacing the interior light bulb .....	35
6132-2	Replacing bulbs for tail/reversing lights .....	35
6130-2	Replacing bulbs for parking lights/direction indicators .....	35

### Group

Op.No.	Description	Page
36108-2	Replacing the direction indicator lever ..	41
36202-2	Replacing the horn .....	42

### Group

Op.No.	Description	Page
36408-2	Replacing the contact for stop lights ..	62
36422-2	Replacing the contact for parking brake ..	63
36424-2	Replacing the contact for brake-pedal travel .....	62
36452-2	Replacing the contact for front-wheel drive .....	63
38108-2	Replacing the speedometer (or tachometer) .....	58
38161-3	Replacing a bulb .....	64
38202-2	Replacing the contact for oil pressure gauge sender .....	61
38230-2	Replacing the temperature gauge sender .....	59
38240-2	Replacing the vacuum contact for diff. locks .....	63