

GROUP 23 FUEL SYSTEM

Description

CARBURETTORS

The engine is fitted with two horizontal carburetors of type Stromberg 175 CD-2SE. The design and construction can be seen from Figs. 23-1, 23-2, 23-3 and 23-4.

The carburettor consists of three main parts of light-alloy, the middle part of which comprises the carburettor housing. The lower section is made up of a floatchamber, which houses the jet and the float. The upper section consists of a suction chamber cover, which forms a suction chamber together with a diaphragm fixed in the air valve. The suction chamber regulates the air valve lift and thereby the location of the needle in the jet. The suction chamber is linked by means of channels in the valve to the space between the carburettor throttle and valve.

The carburetors are provided with a fixed jet pressed into the carburettor housing. The fuel flow orifice area of this jet is varied by means of a movable tapered needle. The position of the needle is deter-

mined by the carburettor housing vacuum operating an air valve in which the needle is fitted in a spring-loaded suspension. The spring force always presses the needle against the same side of the jet, and this ensures an accurately controlled fuel flow through the jet. Both carburetors are fitted with a temperature compensator (6, Fig. 23-2 and 2, Fig. 23-4). This is constructed as an air valve regulated by the carburettor temperature and maintains the fuel-air mixture constant irrespective of the fuel temperature.

The throttle spindles are provided with seals to reduce wear on the spindles and bushings and also to eliminate any air leakage.

The hot-start valve is described on page 23:5.

The front carburettor has a vacuum connection for positive advance setting of the ignition distributor. The rear carburettor is provided with a cold-start device.

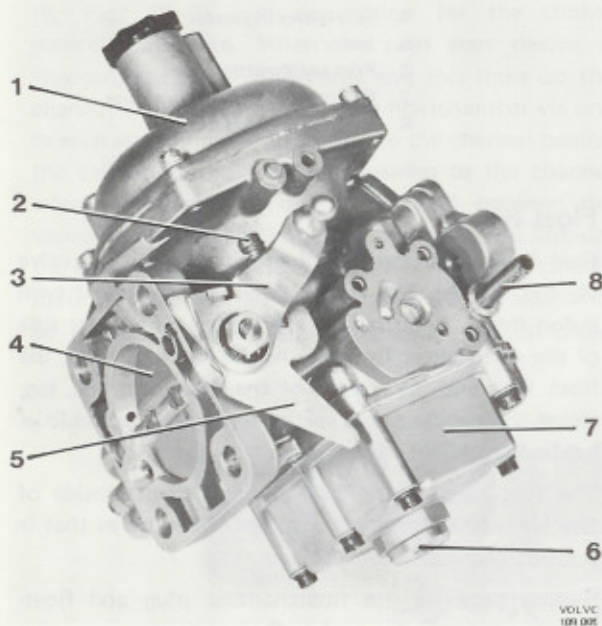

Fig. 23-1. Front carburettor, from left

1. Suction chamber
2. Throttle stop screw
3. Lever
4. Primary throttle
5. Throttle spindle cam (for regulating secondary throttle)
6. Floatchamber plug
7. Floatchamber
8. Fuel inlet

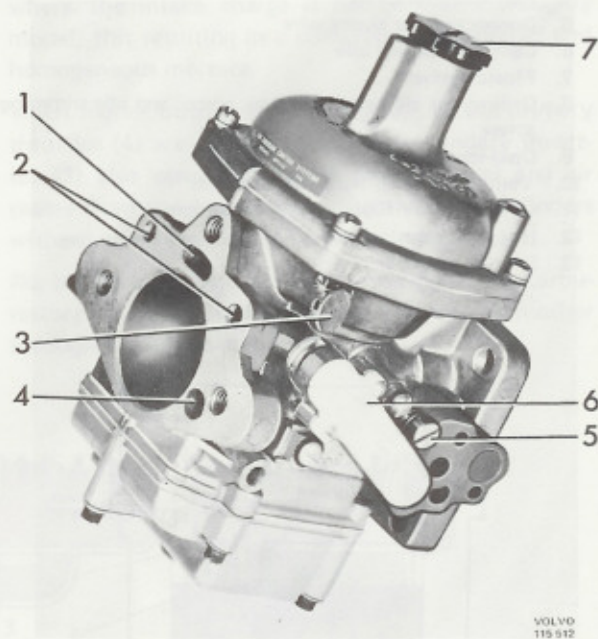

Fig. 23-2. Front carburettor, from right

1. Drilling for air supply under diaphragm
2. Venting channels from floatchamber
3. Sealed plug
4. Drilling for air supply to temp. comp. and idle trimming screw
5. Idle trimming screw
6. Temperature compensator
7. Hydraulic damper

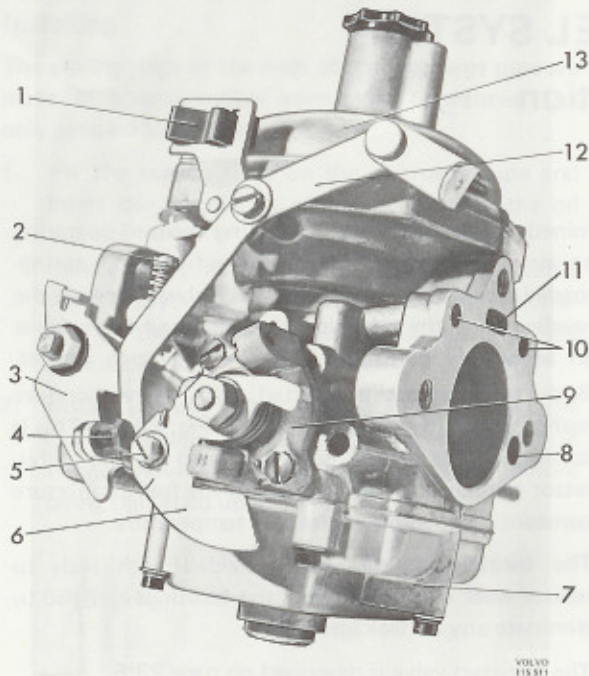

Fig. 23-3. Rear carburettor, from left

1. Clamp for choke wire
2. Throttle stop screw
3. Throttle spindle cam
4. Fast idle stop screw
5. Connection for choke wire
6. Cam disc for fast idle
7. Floatchamber
8. Drilling for air supply to temp. comp. and idle trimming screw
9. Cold-start device
10. Venting channels from floatchamber
11. Drilling for air supply under diaphragm
12. Hot start valve control
13. Suction chamber

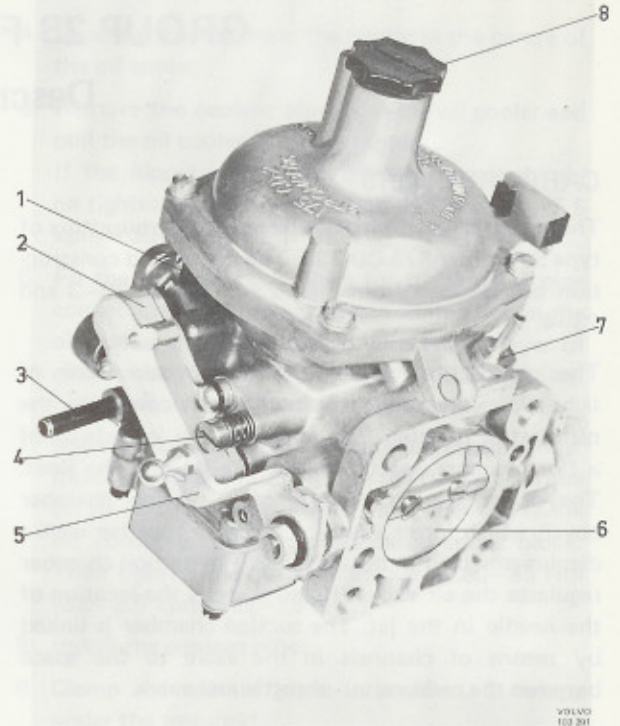

Fig. 23-4. Rear carburettor, from right

1. Sealed plug
2. Temperature compensator
3. Fuel inlet
4. Idle trimming screw
5. Lever
6. Primary throttle
7. Connection for vacuum hose
8. Hydraulic damper

Float system

Fuel flows into the floatchamber via the float valve (4, Fig. 23-5). The float, which is made up of twin nylon floats, is carried on a bridge on the lower side of the carburettor housing. As the fuel level rises, the float lifts and, by means of the float arm and tag, closes the needle on its seating when the correct level has been reached.

The fuel rises in the fuel jet pipe to the inside of the jet, where the level becomes the same as that in the floatchamber.

Sealing between the floatchamber plug and floatchamber is in the form of an O-ring.

Cold start device and fast idle

To make starting easier during cold weather, the rear carburettor is fitted with a cold start device (9, Fig. 23-3).

The cold start device consists of a valve disc (3, Fig. 23-6) provided with four calibrated holes and an elongated opening as well as a disc (4) mounted on a spindle which is operated by the choke. Outside the

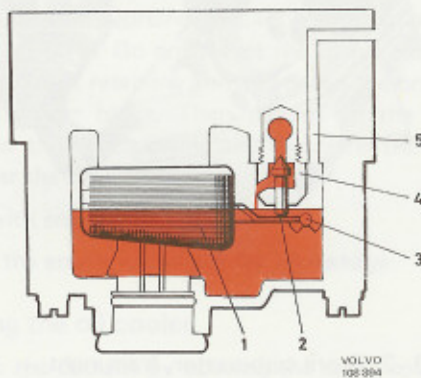

Fig. 23-5. Float system

1. Float
2. Float arm
3. Float shaft
4. Float valve
5. Venting channel from floatchamber to air cleaner

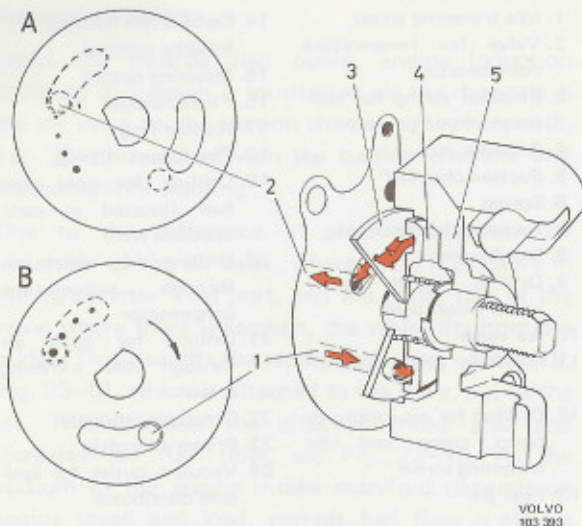

Fig. 23-6. Cold start device

- A. Cold start device, disengaged
 B. Cold start device, engaged
1. From floatchamber
 2. To ventury
 3. Valve disc
 4. "Channel Disc"
 5. Housing

housing (5) on the same spindle, there is a cam disc (6, Fig. 23-3) with connection for the choke control pull wire. When the cold start device is engaged, the valve disc turns and this links up the channel (1, Fig. 23-6) from the floatchamber via one or several of the calibrated holes to the channel behind the valve disc and then the opening to the channel which terminates in the ventury (2) between the vacuum plunger and choke flap. Through this link-up, the engine receives extra fuel (richer mixture), to facilitate cold starts. At the same time a small supply of air is also obtained through the choke device. When

the choke is pushed in, the valve disc turns and closes the inlet to the channel. At the same time the cam disc is operated, the throttle flap opening is also influenced in such a way that turning the cam disc opens the throttle through the fast idle stop screw (4, Fig. 23-3) and the lever, before any of the calibrated holes open the connection to the fuel drilling. Thanks to this arrangement, the idling speed can if necessary be raised by the driver of the vehicle during the warming-up period of the engine.

Exhaust emission control system

The engine is fitted with an exhaust emission control system in accordance with the principle of a more complete combustion which reduces the contents of carbon monoxide and hydrocarbons in the exhaust gases to an acceptable level. This is achieved mainly by a modified induction system that enables a more exact and leaner mixture ratio between fuel and air to be used.

How the system works is illustrated in Fig. 23-7.

The intake manifold is fitted with a secondary throttle (3) at each carburettor. For normal driving, (with low power output) the throttles (3) are closed thus forcing the mixture of fuel and air from the carburettors to a central pre-heating chamber (6) where the intake charge is heated and thoroughly mixed, this resulting in a completely evaporated and homogeneous mixture.

When higher output is required, that is, the primary throttles (4) are opened wider, the secondary throttles (3) also open and the mixture of fuel and air passes from the carburettors directly to the cylinders without going through the pre-heating chamber.

No particularly accurate synchronizing of the carburettors is required since they are linked to each other through the intake manifold.

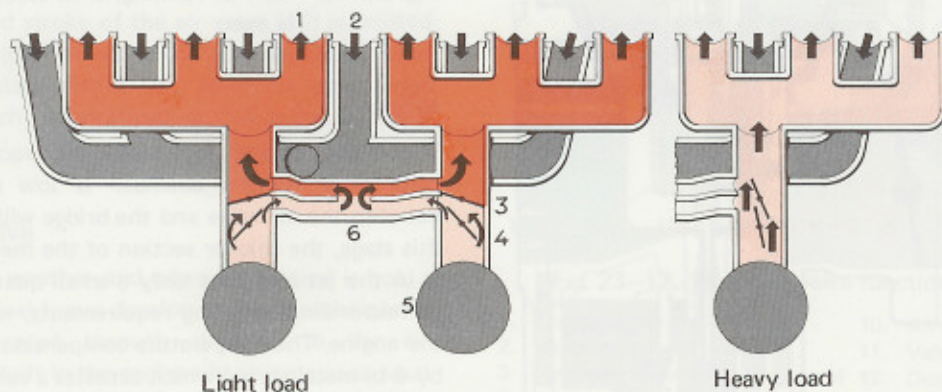

Fig. 23-7. Exhaust emission control system, principle of operation

- | | | |
|---------------------|-----------------------|------------------------|
| 1. Intake manifold | 3. Secondary throttle | 5. Carburettor |
| 2. Exhaust manifold | 4. Primary throttle | 6. Pre-heating chamber |

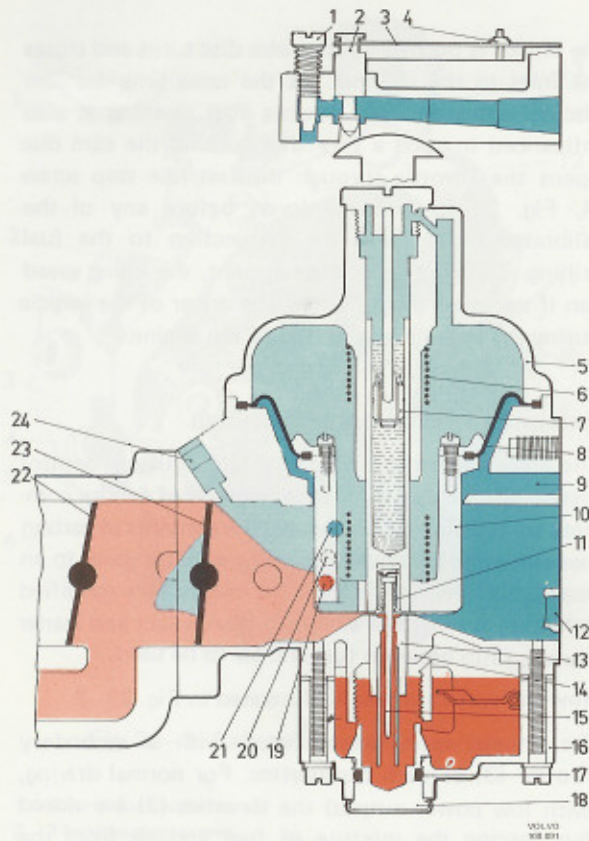

Fig. 23-8. Cold starting, principle

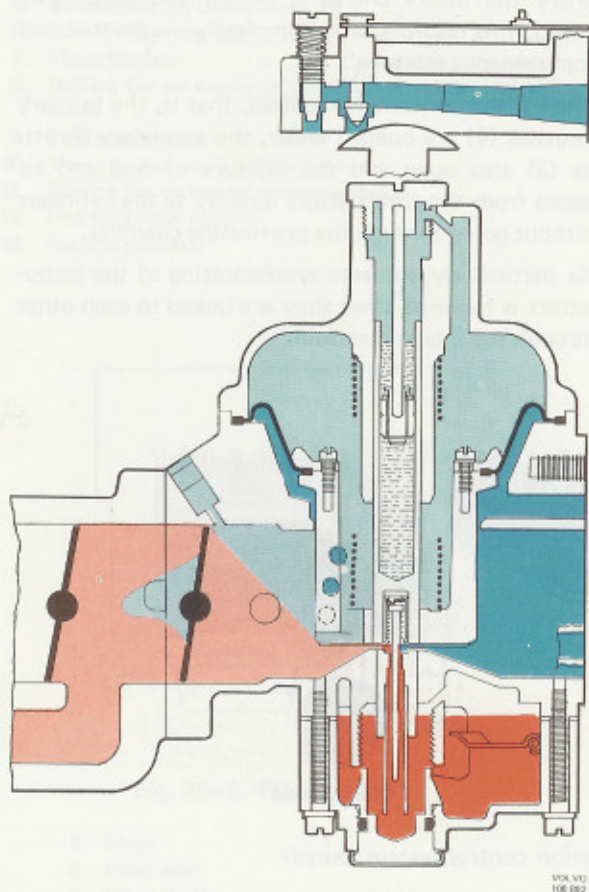

Fig. 23-9. Idling engine

1. Idle trimming screw
2. Valve for temperature compensator
3. Bi-metal spring for temperature compensator
4. Adjuster nut
5. Suction chamber
6. Spring
7. Damper plunger
8. Diaphragm
9. Drilling for air supply under diaphragm
10. Air valve
11. Metering needle suspension
12. Drilling for air supply to temp. comp. and idle trimming screw
13. Fuel jet
14. Carburettor housing (middle section)
15. Metering needle
16. Floatchamber
17. Rubber ring
18. Floatchamber plug
19. Drilling for cold start fuel (located in carb. opposite wall)
20. Drilling for extra air through temperature compensator
21. Drilling for extra air through idle trimming screw
22. Secondary throttle
23. Primary throttle
24. Vacuum outlet for ignition distributor

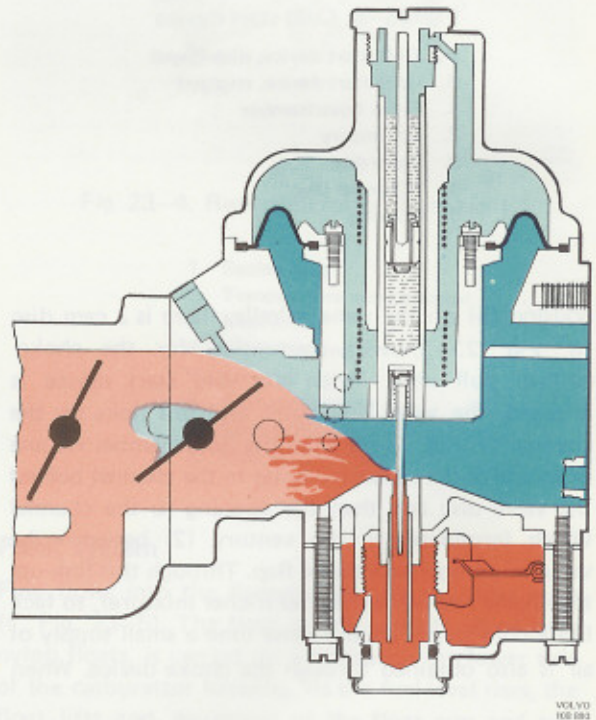

Fig. 23-10. Normal running, with secondary throttle open

Idling

When the engine is idling, the vacuum in the carburettor suction chamber is low and the gap between the air valve and the bridge will be small. At this stage, the thicker section of the metering needle is in the jet and thus only a small quantity of fuel, corresponding to idling requirements, is sucked into the engine. The temperature compensator is regulated by a bi-metal spring which actuates a valve. When the engine is hot and the temperature in the carburettor rises, the valve opens and air is supplied to the carburettor ventury to compensate for the increase in the fuel flow, which is obtained due to the alteration in the fuel's viscosity, see Fig. 23-9.

Normal running

When the throttle flap opens, engine induction manifold depression is transferred via the channels in the air valve to the suction chamber. Diaphragm (8, Fig. 23-8) seals between the suction chamber and the carburettor housing.

Due to the difference in pressure between the underside of the air valve, where there is pressure in the carburettor inlet port, and the upper side of the valve, where there is vacuum, the valve lifts from the bridge. This also lifts the tapered metering needle (15, Fig. 23-8), which is attached to the valve, out of the jet. This increases the effective choke area and increases the fuel flow, see Fig. 23-10. As the vacuum in the engine intake manifold depends on engine speed and load, correct fuel flow is always obtained under all operating conditions.

Because of the variable choke area between the bridge and the valve, the air velocity and pressure drop across the jet orifice will always remain approximately constant, thus ensuring good fuel atomization at all speeds.

Acceleration

To provide a temporarily richer mixture at any point in the throttle range at the moment the throttle is suddenly open, a hydraulic damper is arranged inside the valve rod. The hydraulic damper consists of a plunger mounted on a rod. The plunger works in oil. When the throttle is suddenly opened, the vacuum in the suction chamber increases rapidly.

When the air valve (10, Fig. 23-8) lifts, the damper plunger (7) is forced against its seat and oil is prevented from flowing past from the bottom side to the top of the damper plunger, this retarding the movement of the valve (10). This temporarily results in a more powerful vacuum above the jet so that the fuel-air mixture becomes for the moment richer.

The downward stroke of the air valve (10) is assisted by the spring (6). The rod in the valve should be filled to approximately within 1/4" from the upper edge with oil which is approved as "Automatic Transmission Fluid".

Hot start valve

During warm weather and when the engine is hot, a great deal of fuel fumes develop in the floatchambers. These are vented through channels to the air cleaner and result in the engine obtaining a somewhat "richer" fuel-air mixture. This makes it difficult to start the engine. To counteract this, the hot start valve is fitted to the connection between the floatchamber and air cleaner by means of hoses (Fig. 23-11).

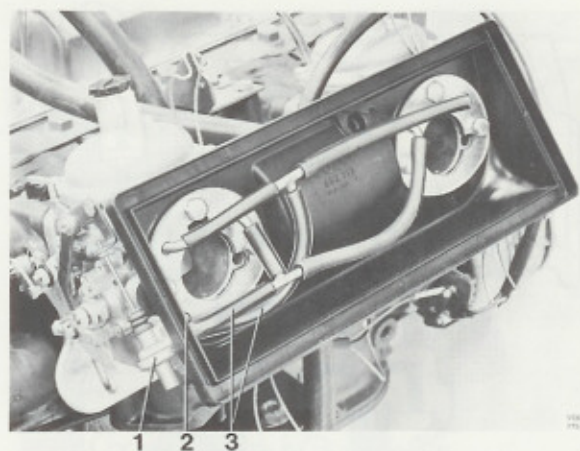

Fig. 23-11. Hose connection for hot start valve

1. Hot start valve
2. Outlet to air cleaner
3. Hoses to carburetors floatchamber

When the throttle is at idle, the lever (1, Fig. 23-12) presses against the valve control. The piston (14) is thereby lifted to its upper position by the control rod. The connection between the floatchamber and air cleaner is closed and fuel fumes are led directly out into the atmosphere through the outlet (12).

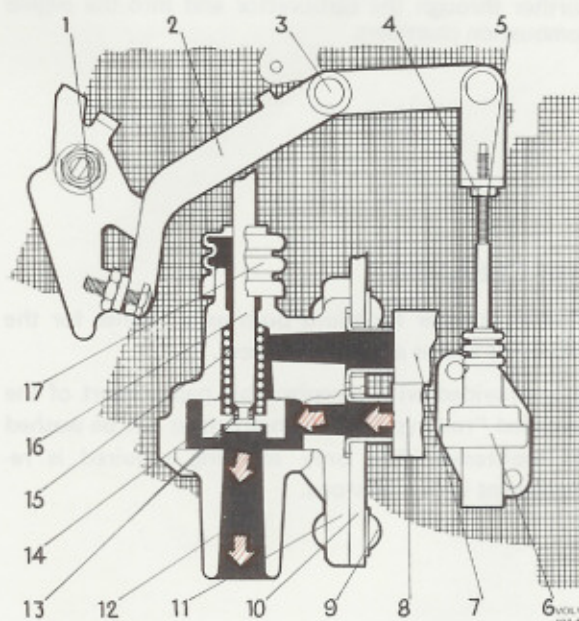

Fig. 23-12. Hot start valve function, idling

- | | |
|--------------------------------------|--------------------------|
| 1. Throttle lever | 10. Air cleaner housing |
| 2. Valve control | 11. Valve housing |
| 3. Retaining screw for valve control | 12. Outlet to atmosphere |
| 4. Lock nut | 13. Rubber rings |
| 5. Control rod | 14. Piston |
| 6. Hot start valve | 15. Return spring |
| 7. Outlet to air cleaner | 16. Control rod |
| 8. Hose to floatchamber | 17. Rubber seal |
| 9. Rivet | |

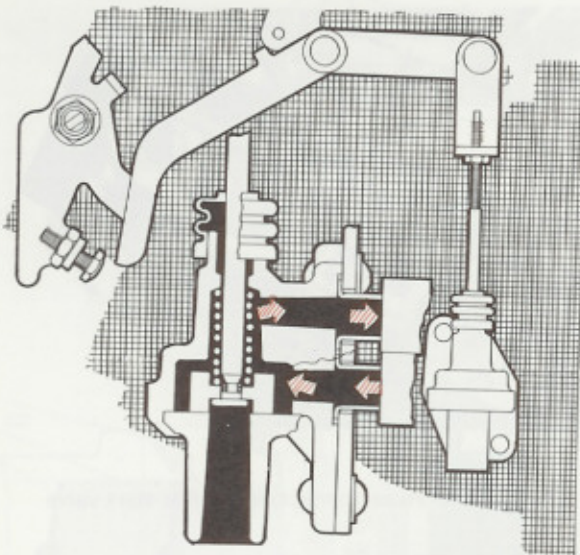

Fig. 23-13. Hot start valve function, driving

When the accelerator pedal is depressed, the throttle control lever (1, Fig. 23-13) breaks contact with the valve control and the piston (14) is pressed by the spring (15) to its bottom position. The outlet (12) is shut off, fuel fumes are led into the air cleaner, and when the engine starts running, these fumes are led further through the carburettor and into the engine combustion chambers.

AIR CLEANER

The air cleaner functions both as a cleaner for the intake air and as an intake silencer.

It is provided with a replaceable paper insert of the so-called "rod type". This insert must not be washed or moistened. The only servicing required is replacement with a new one.

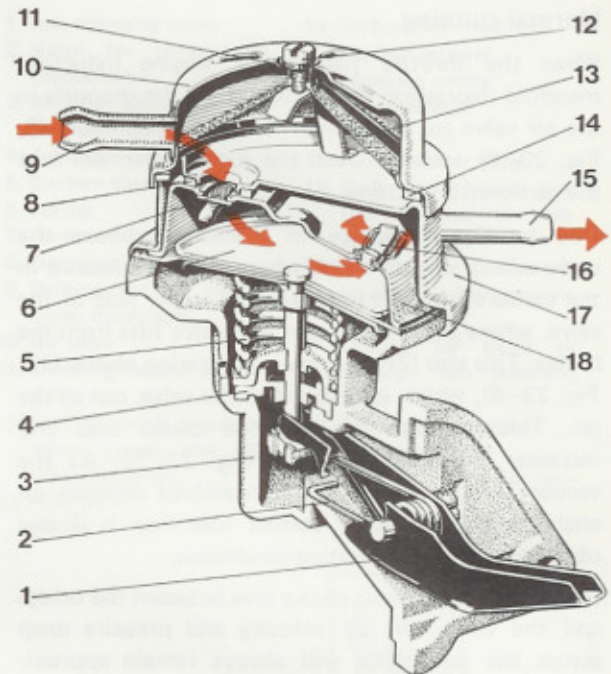

Fig. 23-14. Fuel pump, Pierburg

- | | |
|--------------------|---------------------|
| 1. Rocker arm | 10. Cover |
| 2. Spring | 11. Washer |
| 3. Lower pump body | 12. Screw |
| 4. Seal | 13. Filter |
| 5. Spring | 14. Sealing ring |
| 6. Diaphragm | 15. Outlet |
| 7. Inlet valve | 16. Outlet valve |
| 8. Sealing ring | 17. Upper pump body |
| 9. Inlet | 18. Valve housing |

FUEL PUMP

The fuel pump is of the diaphragm type and is driven by a cam on the camshaft. When the rocker arm in the pump is pressed upwards by the cam, the diaphragm is pulled downwards and fuel is drawn up to the pump. When the rocker arm returns, the diaphragm is pressed upwards by a spring (5, Fig. 23-14) and fuel is fed to the floatchamber in the carburettor. When the level in the floatchamber is sufficiently high, the float valve closes and the pressure in the discharge line rises until the pressure on the upper side of the diaphragm exceeds the spring pressure and pumping ceases.

Two alternative fuel pumps are used. One comes from Pierburg (Fig. 23-14) and the other is a S.E.V. make (Fig. 23-15).

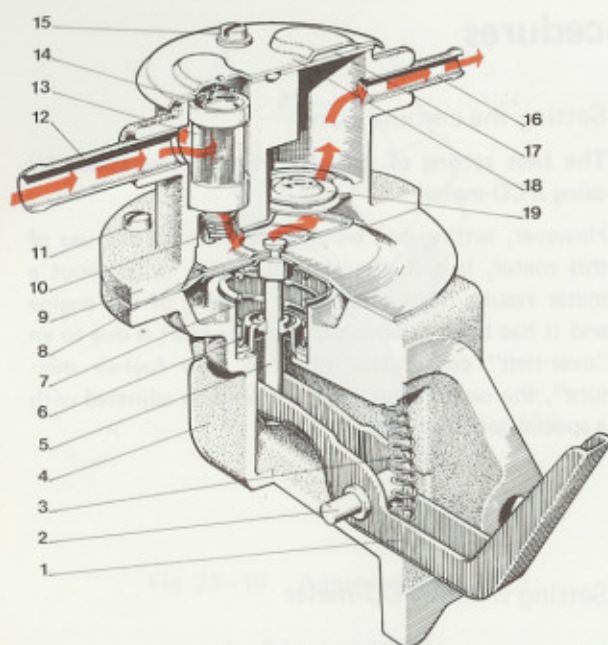

Fig. 23-15. Fuel pump, S.E.V.

- | | |
|--------------------|------------------|
| 1. Lever | 11. Screw |
| 2. Shaft | 12. Inlet |
| 3. Spring | 13. Filter |
| 4. Lower pump body | 14. Spring |
| 5. Thrust rod | 15. Screw |
| 6. Seal | 16. Outlet |
| 7. Spring | 17. Seal |
| 8. Diaphragm | 18. Cover |
| 9. Upper pump body | 19. Outlet valve |
| 10. Inlet valve | |

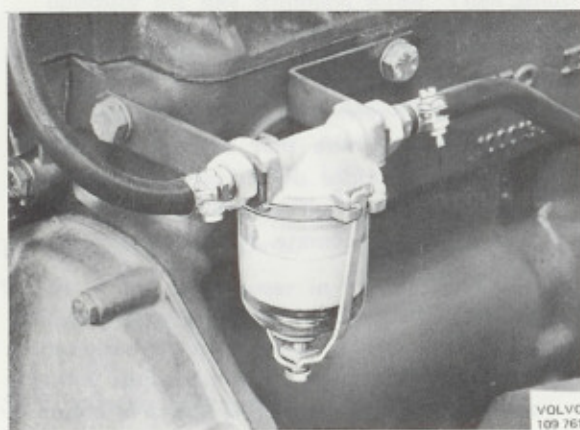

Fig. 23-16. Fuel filter

FUEL FILTER

The fuel filter is fixed to the front of the cylinder block by means of brackets, see Fig. 23-16. It is provided with a replaceable ceramic insert.

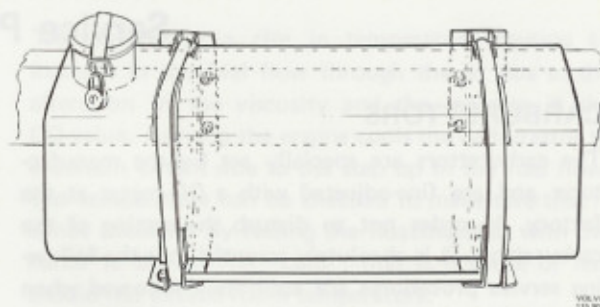

Fig. 23-17. Fuel tank

FUEL TANK AND FUEL LINES

The filler pipe is provided with a strainer to prevent impurities getting into the fuel tank.

Concerning the tank level gauge unit, see Part 3, Group 38.

Service Procedures

CARBURETTORS

The carburetors are specially set by the manufacturer and are fine-adjusted with a CO-meter at the factory. In order not to disturb the setting of the carburetors, it is absolutely essential that **the following service procedures are accurately followed when any work is to be done on the carburetors.**

Periodical Check

Check regularly to see that there is oil in the damper cylinders (Fig. 23-18). The spindle in the piston should be filled to about 1/4" from the upper edge with oil approved as "Automatic Transmission Fluid". **NOTE!** The damper cylinders must not be filled with engine oil.

Before any adjustment or repairs to the carburettor are carried out, the following should be checked and, if necessary, remedied:

Valve clearance, spark plugs, compression, ignition contact breaker (dwell angle) and ignition setting. Also check that there is no air leakage on the intake side and that the air cleaner is not blocked. The function of the throttle controls should be checked as well.

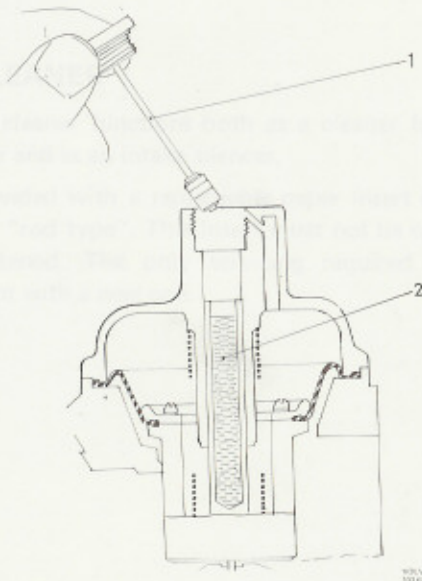

Fig. 23-18. Checking the damper oil level

1. Damper plunger
2. Damper oil (Automatic Transmission Fluid)

Setting the carburetors

The best setting of the carburetors is obtained by using a CO-meter.

However, setting can be checked without the use of this meter, but if the checking with or without a meter results in unsatisfactory running of the engine and it has been established that the fault is due to an "over-rich" carburettor or "too lean fuel-air mixture", the carburettor nozzle should be adjusted with a special tool, see page 23:11.

Setting without CO-meter

1. Remove the floor cover on the platform and the inspection cover on the front engine casing.
 1. Check that there is oil in the damper cylinders. See under "Periodical Check".
 3. Run the engine warm. The adjustment should be carried out within about 10 minutes after the coolant thermostat has opened. (One way of finding this out is by feeling the upper radiator hose at the radiator which should suddenly become hot, approx. 80°C = 176°F.)
 4. Adjust the engine speed to 13.3 r/s (800 r/m) with the throttle stop screws (2, Figs. 23-1 and 23-3).

NOTE! Screw equally for both carburetors. Check to make sure that both carburetors have the same air valve lift. This is easily checked by simply making sure that the distance visually between the bridge of the carburettor housing and the air valve is the same for both carburetors. A more accurate synchronization is not required.
 5. Adjust with the idle trimming screws (5, Fig. 23-2, and 4, Fig. 23-4) from the basic setting (they are screwed to bottom). Adjust with the screws until the best idling speed is obtained. Screw equally for both carburetors.
 6. Adjust the link rods between the carburetors and throttle control shaft. With the control against its stop on the manifold bracket, adjust the link rods to obtain a clearance of approx. 0.1 mm (0.0039") between lever and throttle shaft flange, see Fig. 23-19.

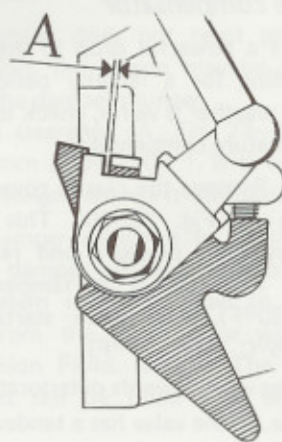

Fig. 23-19. Adjusting the control

A = 0.1 mm (0.0039")

7. Adjust so that the valve control of the hot start valve is against the carburettor lever with the valve piston in the upper position and the throttle control at idle. Lubricate the contact surfaces with Molykote. Rev up the engine, release the control and check that the engine returns to idling speed. Repeat this a couple of times.
8. Setting the fast idle: Pull out the choke 20 mm (0.8"). The mark on the cam disc should now be opposite the idle trimming screw. Then adjust the fast idle screw to give an engine speed of 23.3–25.0 r/s (1400–1500 r/m).
9. Check and if necessary adjust the throttle control to remove play. When accelerator is fully depressed, there should be a play of 1 mm (0.0039") at full throttle. See also point 6.
10. Lubricate all ball joints.
11. Re-fit the floor cover in the platform and the inspection cover.

Setting with CO-meter

The setting should be made at a temperature of +15°C to 25°C (60–80°F) and must be made within 8 minutes after the coolant thermostat has opened. Warming-up should be done with a completely cold engine.

When measuring with a CO-meter, it is important that the temperature of the carburettors is correct. When the engine is idling, the floatchamber is exposed to heat radiation from the exhaust manifold while the flow of cold fuel through the floatchamber is little.

This results in a rise in temperature causing an increase in the fuel flow through the jet due to the alteration in the viscosity and the increase in the CO-value. Revving the engine cools the carburettor to a certain extent due to the step up in the fuel flow. The temperature can be checked to make sure that it is not excessive by feeling the floatchamber with the hand. It should feel "cold", that is it more or less should not exceed room temperature.

Before reading off the CO-meter, briefly rev up the engine so that the air valve is in the proper position. To be certain that the measured CO-value is correct, measuring should be carried out within the time period mentioned above.

There is a number of different types of CO-meters available which function with acceptable accuracy. Instructions on their use are supplied with each meter. Note that when connecting the hose for evacuating the exhaust gases, the hose must not be placed so that the exhaust gases are completely evacuated from the CO-meter connection in the exhaust manifold. A funnel could suitably be used here. With it the suction at the connection would not be so great as to upset the measuring but sufficient to suck up the exhaust gases so that they do not fill the workshop.

When doing any measuring with the CO-meter, it is important that the exhaust pipe and silencer are in good condition, that is, they do not leak. Measure as follows:

1. Remove the floor cover on the platform and the inspection cover on the front engine casing.
2. Check that there is oil in the damper cylinders. They should be filled to about 6 mm (1/4") from the upper edge with Automatic Transmission Fluid. **NOTE!** The damper cylinders must not be filled with engine oil.
3. Connect a tachometer and run the engine warm at 25 r/s (1500 r/m) until the coolant thermostat opens. (One way of finding this out is by feeling the upper radiator hose at the radiator which should start to get hot.)
4. Adjust the engine speed to 13.3 r/s (800 r/m) with the throttle stop screws (2, Figs. 23-1 and 23-3).

NOTE! Screw equally for both carburettors. Check that both carburettors have the same air valve lift. This is easily checked by measuring with the eye the distance between the carburettor housing bridge and the air valve. The distance should be the same for both carburettors. More accurate synchronization is not required.

5. Connect a CO-meter and check the CO-content which should be 2.5%. **NOTE!** Before each reading, rev up the engine briefly. With the help of the idle trimming screws (5, Fig. 23-5) the CO-content can be adjusted with small deviations. (If the CO-content is too high, first check the temperature compensator, see under "Temperature compensator" on page 23:15.
6. Adjust the link rods between the carburettors and the throttle control shaft. With the control against its stop on the manifold bracket, the link rods should be adjusted so that there is a clearance of about 0.1 mm (0.0039") between the lever and the flange of the throttle spindle. See Fig. 23-19.
7. Adjust so that the valve control of the hot-start bar is against the carburettor lever with the valve piston in the upper position and the throttle control at idle. Lubricate the contact surface with Molykote. Rev up the engine. Release the control and check that the engine returns to idling speed. Repeat this a couple of times.
8. Setting the fast idle: Pull out the choke 20 mm (0.8"). The mark on the cam disc should now be opposite the idle trimming screw. Then adjust the fast idle screw to give an engine speed of 23.3-25.0 r/s (1400-1500 r/m).
9. Check and if necessary adjust the throttle control to remove play. When accelerator pedal is fully depressed, there should be a play of 1 mm (0.0039") at full throttle. See also point 6.
10. Lubricate all ball joints.
11. Install the floor cover in the platform and the inspection cover.

Faulty carburettor function

1. Check to make sure that the reason for the fault in the function is not due to wrong damper oil or oil level, impurities in the floatchamber or a faulty float valve and float. See the respective headings.
2. Remove the air cleaner insert and check that the air valves operate easily without jamming. (The damper plungers removed.) If this is not the case, remove the suction chamber covers and clean the valves. At the same time check to make sure the diaphragm is in good condition.
NOTE! If the metering needle must be released or removed, it should be adjusted, see under "Replacing the metering needle". **A CO-meter is recommended for this purpose.**

Temperature compensator

3. If there is a powerful drop in the idling speed during idling for a lengthy period, especially when the weather is warm, check the function of the temperature compensator.

Checking: Remove the plastic cover and push in the valve (3, Fig. 23-20). This should move under very light pressure and return without jamming. This applies at temperatures above +26°C (80°F). The valve starts opening at +20°C-25°C (70°-77°F).

Pressing the valve inwards deteriorates the quality of the idle. If the valve has a tendency to be stiff or jam, it can be adjusted, providing it is not scored or lined, on which occasions it should be replaced complete. See under "Replacing the temperature compensator" on page 23:15.

Adjusting: Slacken one of the cross-slotted screws (8, Fig. 23-20) for the bi-metal spring and centre the valve. The valve should move under very little pressure and return without jamming. This applies at temperatures above +26°C (80°F). Then remove the temperature compensator from the carburettor and store it at a temperature of +20°C-25°C (70°-77°F) until it reaches this temperature. The valve should just start to open at this temperature. In other words, the valve should be loose in its seat at this temperature. If necessary adjust with the nut (9, Fig. 23-20).

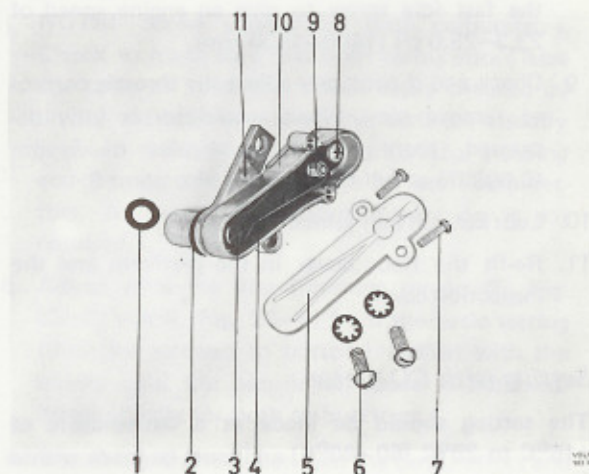

Fig. 23-20. Temperature compensator

- | | |
|--------------------|---------------------------------------|
| 1. Rubber sel | 6. Screws for temperature compensator |
| 2. Rubber sel | 7. Cover screw |
| 3. Valve | 8. Cross-slotted screw |
| 4. Bi-metal spring | 9. Adjuster nut |
| 5. Cover | 10. Housing |
| | 11. Marking |

Damper device

4. If the engine does not react properly during acceleration, the reason may be a faulty clearance on the damper plunger.

The axial clearance (A, Fig. 23-21), should be 1.0–1.8 mm (0.04–0.07"). With any fault in the damper plunger, change it complete.

If the damper device is to function properly, then the damper oil level must be correct. The plunger stem must be filled to about 6 mm (1/4") from the upper edge with Automatic Transmission Fluid. **NOTE!** The damper cylinders must not be filled with engine oil.



Fig. 23-21. Damper plunger clearance

A = 1.0–1.8 mm (0.04–0.07")

Adjusting the fuel jets

Special tools:

2895	Press tools, 2 (1 per carburettor)
2896	Spacer drift
2897	Press tool

1. Remove the floor cover in the platform and the inspection cover on the front engine casing.
2. Remove the upper part of the air cleaner and the cleaner insert.
3. Screw in the idle trimming screws to the bottom.
4. Remove the plugs in the floatchambers by inserting a screwdriver between the floatchamber cover and the plug and by levering out the plug. Screw tight the press tool 2895 in the floatchamber covers, Fig. 23-22.

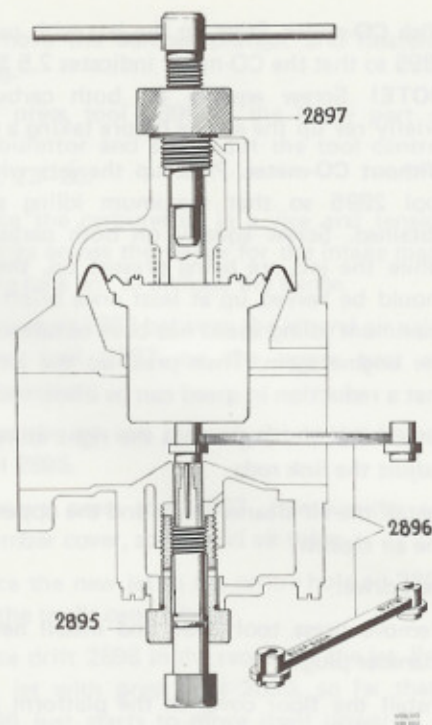

Fig. 23-22. Adjusting the fuel jet

5. Place spacer drift 2896 between the air valve and jet on one of the carburettors.
NOTE! The marking on the drift should face upwards. Use the drift marked B 20 B on the end. Check to make sure that there is a clearance between the drift shoulder and the carburettor housing bridge. If none exists, press up the the jet with press tool 2895 in order to obtain such a clearance. Then unscrew the spindle several turns so that the jet can be pressed down.
6. Remove the damper plunger and screw tight press tool 2897.
7. Press down the jet by screwing in the spindle on tool 2897 so far that the shoulder on the drift goes against the carburettor housing bridge (the carburettor is now adjusted to give "rich" fuel-air mixture).
8. Remove the upper press tool and spacer drift. Install the damper plunger.
9. Carry out points 5, 6, 7 and 8 on the other carburettor.
10. Connect a rev counter and possibly a CO-meter. Run the engine warm until the coolant thermostat opens. The adjustment (that is points 11 and 12) should be carried out within 8 minutes from the time the thermostat opens.
11. Adjust idling speed to 13.3 r/s (800 r/m). Check that the air valves have the same lift (correct with the idle trimming screws).

- 12a. **With CO-meter.** Press up the jets with press tool 2895 so that the CO-meter indicates 2.5 %.
- NOTE!** Screw equally for both carburetors. Briefly rev up the engine before taking a reading.
- 12b. **Without CO-meter.** Press up the jets with press tool 2895 so that maximum idling speed is obtained. Screw equally on both carburetors. While the jets are being pressed up, the engine should be revved up at least once briefly. When maximum idling speed has been obtained, rev up the engine again. Then press up the jets so far that a reduction in speed can be discerned.
13. Check that the engine has the right idling speed. Adjust the link rods.
14. Install the air cleaner insert and the upper part of the air cleaner.
15. Test drive.
16. Remove press tool 2895 and install new float-chamber plugs.
17. Install the floor cover in the platform and the inspection cover.

Checking the secondary throttles

Check to make sure that the secondary throttles are centred and can be turned without jamming. Check the location ("A", Fig. 23-23) of the levers. When the secondary throttle is closed, the distance "A" between the lever pin and the intake manifold flange should be 2.7-4.3 mm (0.11-0.17").

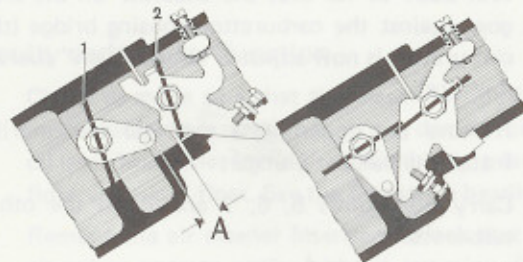

Throttle position at low output Fully open throttle

Fig. 23-23. Throttle position

1. Secondary throttle
2. Primary throttle
- A. 2.7-4.3 mm (0.11-0.17")

Removing the carburetors

1. Remove the floor cover in the platform and the inspection cover on the front engine casing.
2. Remove the hot start valve control from the rear carburettor. Remove the air cleaner.
3. Remove the ball joints of the link rods from the carburetors.
4. Remove the fuel hose, vacuum hose and choke wire from the carburetors. Remove the retaining nuts for the carburetors. Remove the carburetors and the protective plates and gaskets. Cover the holes in the intake manifold.

Replacing the diaphragm

1. Screw out the damper plunger. Make line-up marks in the suction chamber cover and carburettor housing. Remove the screws and lift off the suction chamber cover. Remove the spring.
2. Pull up the air valve with the diaphragm. Remove the diaphragm by releasing the four screws. Clean the air valve.

NOTE! Take care not to bend or displace the needle.

3. Install the new diaphragm, Fig. 23-24. The rubber register should fit into the valve groove.



Fig. 23-24. Diaphragm in air valve

4. Move the air valve down and fit in the rubber register, Fig. 23-25. Install the spring and cover. Fill with damper oil (Automatic Transmission Fluid). **NOTE!** The damper cylinders must not be filled with engine oil.
5. Install the suction chamber cover and the damper plunger.

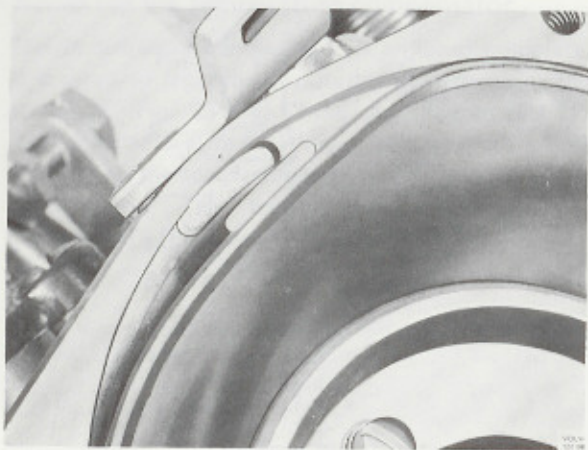

Fig. 23-25. Diaphragm in carburettor housing

Replacing the fuel jet

Special tools:

2895	Press tool
2896	Spacer drift
2897	Press tool
2962	Drift

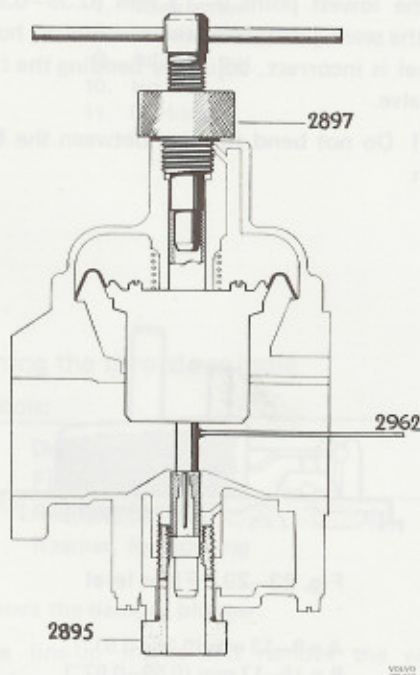

Fig. 23-26. Replacing the fuel jet

1. Remove the damper plunger and float chamber plug.
 2. Fit press tool 2895 in the lower part of the carburettor and screw out the tool centre bolt, Fig. 23-26.
 3. Place the carburettor in a vice and tension the shanks across the flange for the intake manifold. Take care not to damage the flange.
 4. Place drift 2962 between the jet and air valve. Fit press tool 2897 on the upper part of the carburettor.
 5. Press the jet out through the centre hole in the tool 2895.
 6. Remove press tool 2897. Remove the suction chamber cover, spring and air valve.
 7. Place the new jet in the centre hole on 2895 and fit the tool's centre bolt.
 8. Place drift 2896 in the recess for the jet. Press up the jet with press tool 2895, so far that drift 2896 just starts to move itself upwards. Screw out the tool centre bolt a couple of turns.
 9. Replace the metering needle. See under "Replacing the metering needle", below.
 10. Install the air valve, spring and cover. Fill with damper oil (Automatic Transmission Fluid) and fit the damper plunger.
- NOTE!** The damper cylinders must not be filled with engine oil.
11. Install the carburettor on the engine and adjust the fuel jet according to the instructions given under "Adjusting the fuel jet", points 10-16, page 23:11.

Replacing the metering needle

After replacing the metering needle, the following check with a CO-meter is recommended.

1. Remove the vacuum chamber cover. Take out the air valve and clean it.
2. Remove the needle by unscrewing the lock screw and pull the needle out together with the spring suspension.
3. Before installing the new needle, check that the needle designation is B 2 BA. This is punched on the needle and can be seen by pulling the needle out of the spring suspension far enough to reveal it.

4. Install the needle together with the spring suspension so that the flat surface faces the lock screw. The needle should incline from the holes in the air valve, that is, in towards the air cleaner flange.

The needle should be inserted so far that the plastic washer lies flush with the valve, see Fig. 23-27.

Tighten up the lock screw.

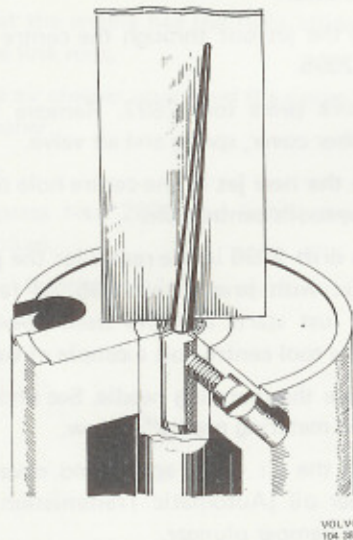

Fig. 23-27. Installing the metering needle

5. Install the air valve in the carburettor.
NOTE! Fit the diaphragm according to Fig. 23-25.
6. Install the vacuum chamber cover.

Cleaning the floatchamber

1. Remove the screws (1, Fig. 23-28).
2. Remove the floatchamber.
3. Clean the surface of the gasket using compressed air.
4. Install the floatchamber with new gasket.
NOTE! If the floatchamber plug is removed, a new plug must be fitted in order to ensure that it is properly fixed in the floatchamber.

The plug is removed by bending it out with a suitable tool between the floatchamber cover and plug.

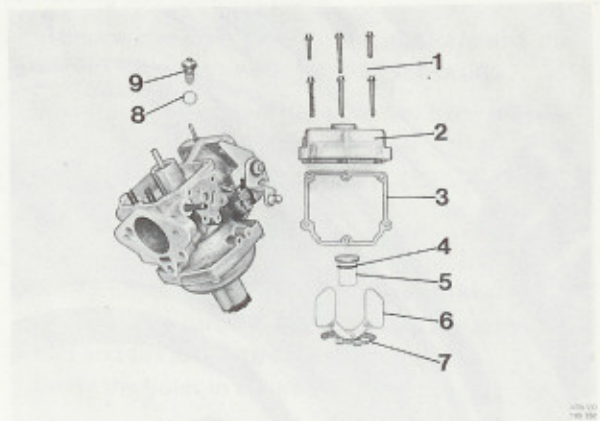

Fig. 23-28. Floatchamber dismantled

- | | |
|----------------------------|-----------------|
| 1. Screws for floatchamber | 7. Float pin |
| 2. Floatchamber | 8. Washer |
| 3. Gasket | 9. Needle valve |
| 4. O-ring | |
| 5. Plug | |
| 6. Float | |

Float level

Before checking the float level, remove the carburettor, invert it and take out the floatchamber.

The float is removed by carefully breaking the float spindle from the bridge. It is fitted with the sloping side facing away from the carburettor housing.

At the correct float level, the top point on the float should lie 15-17 mm (0.59-0.67") (B, Fig. 23-29) with the lowest point 9-13 mm (0.35-0.51") (A) above the sealing surface of the carburettor housing. If the level is incorrect, adjust by bending the tag at the float valve.

NOTE! Do not bend the arm between the float and the pin.

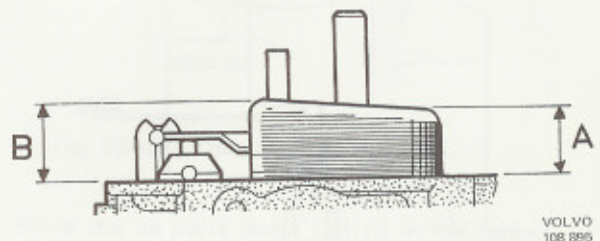

Fig. 23-29. Float level

- A = 9-13 mm (0.36-0.51")
B = 15-17 mm (0.59-0.67")

Replacing the temperature compensator

The temperature compensator is replaced complete. It is removed from the carburettor by unscrewing the screws (6, Fig. 23-30). Take out the old seal (1) from the carburettor and fit a new one. Place a new seal (2) on the temperature compensator and fit the compensator. The temperature compensator is marked "60" (11).

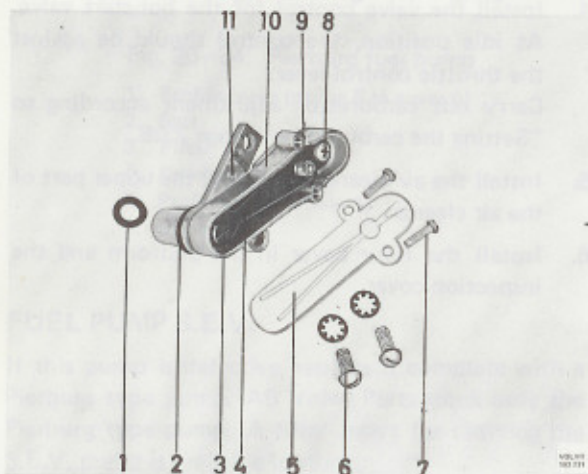

Fig. 23-30. Temperature compensator

1. Rubber seal
2. Rubber seal
3. Valve
4. Bi-metal spring
5. Cover
6. Screws for temperature compensator
7. Cover screw
8. Cross-slotted screw
9. Adjuster nut
10. Housing
11. Marking

Re-bushing the throttle spindle

Special tools:

2402	Drift
2879	Fixture
2880	Reamer, for seat
2881	Reamer, for bushing

1. Remove the damper plunger.
2. Make line-up marks and remove the vacuum chamber cover. Lift out the spring together with the air valve.
3. Remove the float chamber and float.

4. Remove the levers and the return spring from the throttle spindle.
5. Remove the throttle. Knock out the sealing washer together with the old throttle spindle (only front carburettor). Remove the throttle spindle.
6. Remove the spindle seal (seals). Remove the nipple for the upper vacuum outlet (only front carburettor).
7. Fix the fixture in a vice and fit the carburettor on the fixture, Fig. 23-31. Make sure that the fixture pin holes are in line with the holes in the spindle bushings.

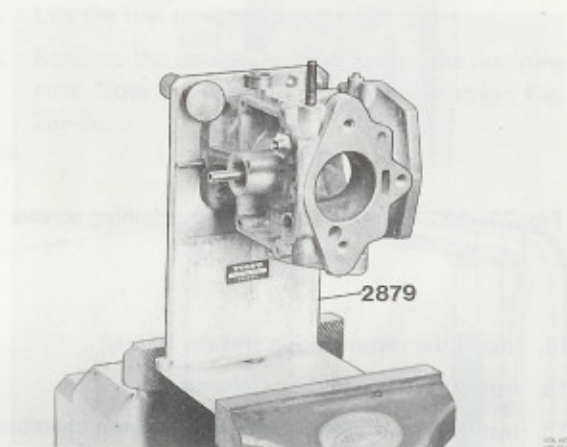

Fig. 21-31. Mounting carburettor on fixture 2879

8. Ream off the old bushings with reamer 2880.
NOTE! Do not pull the reamer back through the bushings but move it in the working direction through the hole in the bottom plate of the fixture.
9. Turn the fixture pin 90° so that it forms a stop internally inside the carburettor housing for the bushings and drive in the bushings with drift 2402.
10. Turn the fixture pin a further 90° so that the holes in the pin come in line with the holes in the bushings. Ream the bushings with reamer 2881.
NOTE! Do not pull the reamer back through the bushings but move it in the working direction through the hole in the bottom plate of the fixture.
11. Remove the carburettor from the fixture. Blow the carburettor clean.
12. Install the seal (seals) and if necessary a sealing washer.

13. Install the throttle and throttle spindle. Centre the throttle and rivet the retaining bolts, Fig. 23-32.

NOTE! The "bosses" on the throttle should face the floatchamber and the manifold flange.

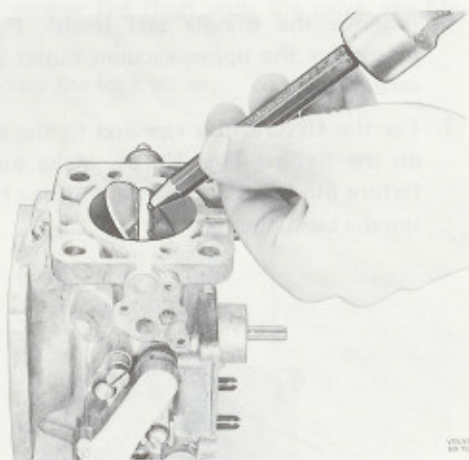

Fig. 23-32. Riveting throttle flap retaining screws

14. Install the return spring and the levers.
15. Install the float and floatchamber.
16. Install the air valve, spring and vacuum chamber.
17. Install the nipple for the upper vacuum output (only front carburettor).

Installing the carburettors

1. Clean the gasket surface. Install the protecting plates, new gaskets, one on each side of the plates, and the carburettors, Fig. 23-33.

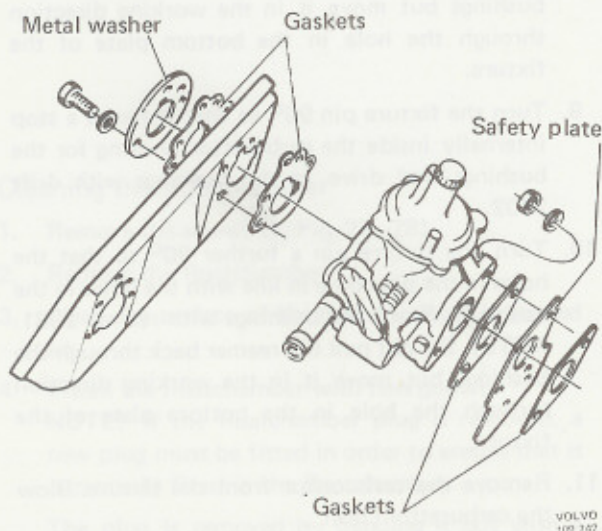

Fig. 23-33. Installing the carburettor

2. Connect the ball joints, fuel hoses, vacuum hose and choke wire. Make sure that the choke control on the instrument panel is pushed in. Then lock tight the pull wire on the rapid idle cam clamping screw. Thereafter fix the pull wire outer sleeve with the clips intended for this purpose.
3. Install the lower part of the air cleaner and the hose for the crankcase ventilation.
4. Install the valve control for the hot-start valve. At idle position, the control should be against the throttle control lever. Carry out carburettor adjustment according to "Setting the carburettors", page 23:8.
5. Install the air cleaner insert and the upper part of the air cleaner.
6. Install the floor cover in the platform and the inspection cover.

Replacing the air cleaner insert

No cleaning etc, need be done between insert changes. Under no circumstances may the insert be moistened or oiled.

A sign of a blocked air cleaner is increased fuel consumption.

FUEL PUMP

Pierburg

If the pump is defective, replace it complete. A filter insert for cleaning is available in stock.

Cleaning (pump removed)

1. Remove the cover retaining screw (1, Fig. 23-34). Lift off the cover (6), the filter (3) and the seal (2).
2. Clean the pump body and cover. Blow clean or replace the filter.
3. Place the gasket and filter in position on the pump body.
4. Install the cover. Make sure that the profiles in the pump body and cover coincide.

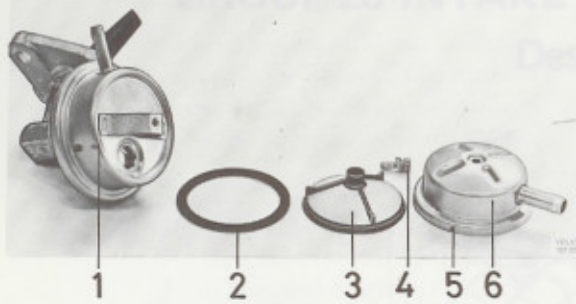

Fig. 23-34. Pierburg fuel pump

1. Profile (suits profile 5 in cover 6)
2. Seal
3. Filter
4. Cover screw
5. Profile (suits profile 1)
6. Cover

FUEL PUMP S.E.V.

If this pump is defective, replace it complete with a Pierburg type pump. AB Volvo Parts stock only the Pierburg type pump. A filter insert for cleaning the S.E.V. pump is available in stock.

Cleaning (pump removed)

1. Remove the cover (1, Fig. 23-35), the spring (5) and the seal (4).
2. Clean the pump body.
3. Remove the filter (6) and blow it clean or replace it.
4. Install the filter. Place the seal with the open part over the filter. Install the spring and cover. The pin (2) in the cover should fit in the spring (5).

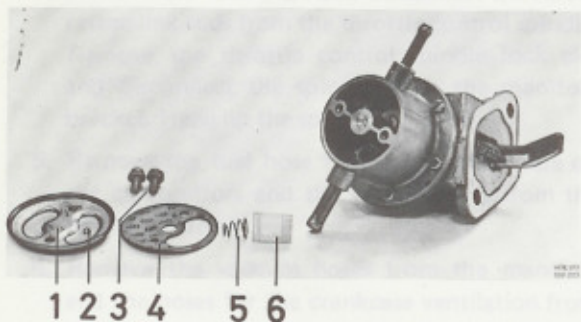

Fig. 23-35. S.E.V. fuel pump

1. Cover
2. Pin for centering spring (5)
3. Cover screws
4. Seal
5. Spring
6. Filter

FUEL TANK

Removing

1. Remove the plug underneath the tank and drain the fuel.
2. Remove the breather hose from the filler pipe.
3. Remove the electric cables from the tank level gauge unit.
4. Remove the fuel pipe from the tank.
5. Remove the tensioning band adjuster nuts.
6. Bend down the tensioning band and remove the fuel tank.

Installing

1. Lift the fuel tank into position.
2. Bend up the tensioning band and fit the retaining nuts. **Note** the location of the rubber strips, Fig. 23-36.

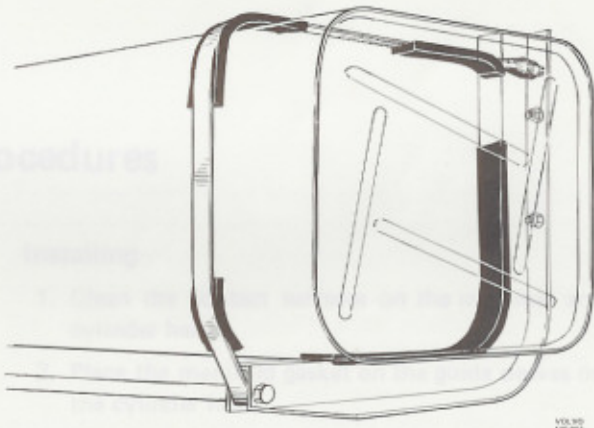

Fig. 23-36. Installing the fuel tank

3. Install the fuel pipe and drain plug.
4. Install the electric cables for the tank fuel level gauge.
5. Install the breather hose on the filler pipe.